

ATRT-03 S2, ATRT-03A S2, and ATRT-03B S2 THREE-PHASE TRANSFORMER TURNS-RATIO METERS

USER'S MANUAL



Vanguard Instruments Company, Inc.

1520 S. Hellman Ave.

Ontario, California 91761, USA

TEL: (909) 923-9390

FAX: (909) 923-9391

August 2010

Revision 2

SAFETY SUMMARY

This manual applies to the ATRT-03 S2, ATRT-03A S2, and ATRT-3B S2 current transformer turns-ratio meters. The operating procedures are virtually the same for all three models, and any differences are clearly described where applicable.

FOLLOW EXACT OPERATING PROCEDURES

Any deviation from procedures described in this User's Manual may create one or more safety hazards, damage the ATRT-03/03A/03B S2, damage the test transformer, or cause errors in the test results. Vanguard Instruments Company, Inc. assumes no liability for unsafe or improper use of the ATRT-03/03A/03B S2.

SAFETY WARNINGS AND CAUTIONS

The ATRT-03/03A/03B S2 shall be used only by **trained operators**. All transformers under test shall be **off-line** and **fully isolated**. Always ground the ATRT-03/03A/03B S2 to a substation ground before connecting the test cables to a transformer. Do not perform test procedures or service unless another person is also present who is capable of rendering aid and resuscitation.

DO NOT MODIFY TEST EQUIPMENT

To avoid the risk of introducing additional or unknown hazards, do not install substitute parts or perform any unauthorized modification to any ATRT-03/03A/03B S2 test unit. To ensure that all designed safety features are maintained, it is highly recommended that repairs be performed only by Vanguard Instruments Company factory personnel or by an authorized repair service provider. Unauthorized modifications can cause safety hazards and will void the manufacturer's warranty.

WARNING

Do not remove test leads during a test. Failure to heed this warning can result in electrical shock to personnel and damage to the equipment.

TABLE OF CONTENTS

CONVENTIONS USED IN THIS DOCUMENT	1
1.0 INTRODUCTION	2
1.1 General Description and Features	2
1.2 Technical Specifications	4
1.2.1. ATRT-03 S2 Technical Specifications	4
1.2.2. ATRT-03A S2 Technical Specifications	5
1.2.3. ATRT-03B S2 Technical Specifications	6
1.3 Controls and Indicators.....	7
2.0 PRE-TEST SETUP	13
2.1 Operating Voltages	13
2.2 LCD Screen Contrast Control.....	13
2.3 Printer Paper Control	13
2.4 Printer Paper	13
2.5 Replacing the Load Tap Changer Controller Fuses	14
3.0 OPERATING PROCEDURES	16
3.1 Connection Diagrams.....	16
3.1.1. Typical Front Panel Connections.....	16
3.1.2. Typical Connections to a Load Tap Changer (LTC).....	17
3.1.3. Typical Connections to a Delta-Wye Transformer.....	18
3.2 Setting the Test Voltage.....	26
3.3 Setting the Date and Time	28
3.4 Performing Tests	29
3.4.1. Entering Test Record Header Information	29
3.4.2. Testing a Single Phase Transformer	33
3.4.3. Testing a Dyn1 (12,000 V/208 V) Transformer.....	42
3.4.4. Testing a Three Phase Transformer Using Auto Detect Mode	52
3.5 Working With Test Records	59
3.5.1. Saving Test Results to a Test Record	59
3.5.2. Restoring a Test Record From Flash EEPROM.....	62
3.5.3. Restoring a Test Record From a USB Flash Drive	67
3.5.4. Copying Test Records to a USB Flash Drive	71
3.5.5. Printing or Displaying a Test Record	74
3.5.6. Printing a Test Record Directory (ATRT-03 S2 and ATRT-03A S2 Only).....	77
3.5.7. Viewing a Test Record Directory on the LCD Screen (ATRT-03B S2 Only)	80
3.5.8. Erasing Test Records from the Flash EEPROM	82
3.5.9. Erasing Test Records from a USB Flash Drive.....	86
3.6 Working With Test Plans.....	89
3.6.1. Performing a Test Using a Transformer Test Plan.....	89
3.6.2. Unloading a Test Plan From the Working Memory.....	96
3.6.3. Printing a Test Plan Directory (ATRT-03 S2 and ATRT-03A S2 Only)	97
3.6.4. Viewing a Test Plan Directory on the LCD Screen (ATRT-03B S2 Only).....	99
3.6.5. Printing a Test Plan (ATRT-03 S2 and ATRT-03A S2 Only)	101

3.6.6. Saving a Test Plan 104

3.6.7. Copying a Test Plan to a USB Flash Drive 106

3.6.8. Erasing Test Plans 108

4.0 DIAGNOSTICS, VERIFICATION, AND TROUBLESHOOTING 112

 4.1 Performing an H and X Cable Diagnostic Test 112

 4.2 Performing a Verification Test 114

5.0 UPGRADING FIRMWARE 116

APPENDIX A – TRANSFORMER VECTOR GROUP CODES 119

APPENDIX B – Common ANSI Transformer Descriptions 120

APPENDIX C – CEI/IEC 60076-1 Transformer Descriptions 128

APPENDIX D – Australian Std.2374 Transformer Descriptions 135

<http://www.51082245.com>

LIST OF TABLES

Table 1. ATRT-03 S2 Technical Specifications	4
Table 2. ATRT-03A S2 Technical Specifications.....	5
Table 3. ATRT-03B S2 Technical Specifications.....	6
Table 4. Functional Descriptions of ATRT-03 S2 Controls and Indicators	8
Table 5. Functional Descriptions of ATRT-03A S2 Controls and Indicators	10
Table 6. Functional Descriptions of ATRT-03B S2 Controls and Indicators	12
Table 7. Descriptions of Single Phase Test Results Elements (Column Format)	39
Table 8. Descriptions of Single Phase Test Results Elements (Detailed Format)	41
Table 9. Descriptions of Dyn1 Test Results Elements (Column Format)	49
Table 10. Descriptions of Dyn1 Test Results Elements (Detailed Format)	51

LIST OF FIGURES

Figure 1. ATRT-03 S2 Controls and Indicators	7
Figure 2. ATRT-03A S2 Controls and Indicators	9
Figure 3. ATRT-03B S2 Controls and Indicators	11
Figure 4. Typical Front Panel Cable Connections.....	16
Figure 5. Typical Connections to a Load Tap Changer (LTC).....	17
Figure 6. Typical H & X Cable Connections to a Delta-Wye Transformer	18
Figure 7. Typical Connections to a Single Phase Transformer	19
Figure 8. Typical Connections to a Single Phase Auto Transformer	19
Figure 9. Typical Connections to a Type A Voltage Regulator	20
Figure 10. Typical Connections to a Type B Voltage Regulator	20
Figure 11. Typical Connections to a Donut Type (un-mounted) Current Transformer (CT).....	21
Figure 12. Typical Connections to a Multi-Tap Current Transformer.....	22
Figure 13. Typical Connections to a Bushing Mount CT on a Single Phase Transformer	23
Figure 14. Typical Connections to Bushing Mount CT's on Delta Transformer	24
Figure 15. Typical Connections to Bushing Mount CT's on Wye Transformer	25
Figure 17. Single Phase Test Results Printout - Column Format	39
Figure 18. Single Phase Test Results Printout - Detailed Format	40
Figure 19. Dyn1 Test Results Printout - Column Format	48
Figure 20. Dyn1 Test Results Printout - Detailed Format	50
Figure 21. Typical USB Flash Drive (Thumb Drive) Test Record Directory Printout	79
Figure 22. Typical Internal Flash EEPROM Test Record Directory Printout.....	79
Figure 23. Test Plan Test Results Printout	95
Figure 24. Sample Printout of a Test Plan from a USB Flash Drive.....	102
Figure 25. Sample Printout of a Test Plan from Internal Memory	103

CONVENTIONS USED IN THIS DOCUMENT

This document uses the following conventions:

- The general term “ATRT” is used in this manual to refer to any of the ATRT-03 S2 models (ATRT-03 S2, ATRT-03A S2, and ATRT-3B S2).
- A key, switch, or knob on the ATRT is indicated as **[KEY]**, **[SWITCH]**, **[KNOB]**.
- Menu names are referenced as “MENU NAME”
- ATRT LCD screen output is shown as:

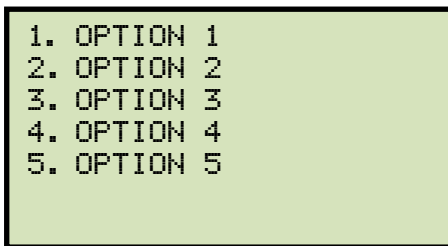

- When instructions are provided, the menu item that should be selected is outlined with a rectangle as shown below (option 3 should be selected):

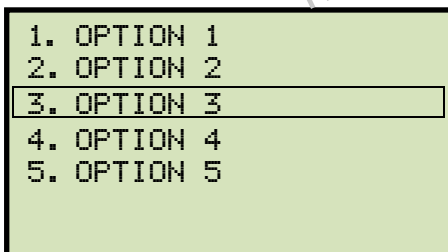

- Warning messages are indicated as:



- Important notes are indicated as:



1.0 INTRODUCTION

1.1 General Description and Features

The ATRT-03 S2 line is Vanguard's third generation family of microprocessor-based, automatic, three phase, transformer turns-ratio testers. The ATRT-03 S2 line consists of the following three models:

- The ATRT-03 S2 is a line-powered, 100-240 Vac, 50/60 Hz turns-ratio tester featuring a built-in thermal printer.
- The ATRT-03A S2 can be powered either by an internal rechargeable lead acid battery, by 100-240 Vac, or by a 12 Vdc external source. The internal battery provides 3 hours of operational time. The ATRT-03A S2 also features a built-in thermal printer.
- The ATRT-03B S2 is a line-powered, 100-240 Vac, 50/60 Hz turns-ratio tester without a built-in thermal printer.

The general term "ATRT-03 S2" or "ATRT" is used in this manual to refer to any of the ATRT-03 S2 models. Any differences are clearly described where applicable.

The ATRT-03 S2 determines the transformer turns-ratio using the IEEE C57.12.90 measurement method. The ATRT-03 S2 outputs an excitation test voltage to the transformer's primary windings. The induced secondary voltage is sensed and the transformer turns-ratio is calculated. The unit can measure turns-ratios from 0.8 to 15,000. The transformer turns-ratio, excitation current, and phase-angle readings are displayed on the large back-lit LCD. The built-in transformer type detection feature allows the ATRT-03 S2 to detect and test 130 transformer types defined by ANSI, CEI/IEC and Australian standards.

The ATRT-03 S2 can be used as a stand-alone unit or can be computer-controlled. It can be operated locally using its alpha-numeric keypad and rotary switch. Information is displayed on a back-lit LCD screen (64 x 128 dot graphic) that is viewable in both bright sunlight and low-light levels. Test reports can be printed in the field on the unit's built-in 4.5-inch wide thermal printer (ATRT-03 S2 and ATRT-03A S2 only). The ATRT-03 S2 can store up to 112 test records and 128 test plans in Flash EEPROM. Test records or test plans can be stored or transferred to and from a PC via the available interfaces (RS-232C port, USB port, USB Flash drive port).

Transformer Test Voltage

To prevent an accidental wrong test-lead hook-up (e.g., when the operator reverses H and X leads), the ATRT-03 S2 outputs a low-level test voltage to verify the hook-up condition before applying the full test voltage to the transformer. Three test voltages (8 Vac, 40 Vac, 100 Vac) allow the ATRT-03 S2 to test CT's and PT's, as well as power transformers.

Auto-Detect Transformer Configuration

The ATRT-03 S2 can automatically detect 130 specific vector groups for different transformer types defined by ANSI, CEI/IEC, and Australian standards.

User Interface

The ATRT-03 S2 features a back-lit LCD screen (64 x 128 dot graphic) that is viewable in both bright sunlight and low-light levels. The test results screen displays the transformer turns-ratio, excitation current, phase angle, and percentage error. The unit is controlled via a rugged, 16-key, membrane keypad and a digital rotary switch.

Transformer Test Plans

The ATRT-03 S2 can store up to 128 transformer test plans in its Flash EEPROM. A test plan is comprised of the transformer nameplate voltages for each tap setting. The calculated turns-ratio based on the nameplate voltages is compared with the measured turns-ratio. By recalling a test plan, a transformer can be quickly tested and turns-ratio Pass/Fail reports can be reviewed. Test plans can be created with the PC software and can be transferred to the ATRT-03 S2 via the available interfaces (RS-232C port, USB port, USB Flash drive port).

Internal Test Record Storage

Up to 112 test records can be stored in the ATRT-03 S2's Flash EEPROM memory. Each test record may contain up to 33 turns-ratio, excitation current, phase angle and name plate voltage readings. Test records can be recalled locally or transferred to a PC via the available interfaces (RS-232C port, USB port, USB Flash drive port).

USB Flash Drive Interface

A built-in USB Flash drive interface provides a convenient method for transferring test plans and test records to or from a USB Flash drive. The user can store up to 999 transformer test plans on a USB Flash drive. Test plans can be transferred from a PC to a USB Flash drive, and then a specific test plan on the USB Flash drive can be transferred to the ATRT-03 S2's internal Flash memory. Up to 999 test records from the field can be stored on a USB Flash drive. Test records stored in the ATRT-03 S2's internal memory can also be transferred to a USB Flash drive. The supplied PC software can then be used to view the test records stored on the USB Flash drive.

Computer Interface

In computer-controlled mode, the unit can be controlled via the RS-232C or USB port using the supplied PC software (Transformer Turns-Ratio Analyzer application provided with each ATRT-03 S2). This Windows® XP/Vista-based software can be used to run a test and to store test results on a PC. Test results can also be exported to Microsoft® Excel.

Transformer Load Tap Changer Control

Transformer tap positions can be changed remotely using the unit's built-in transformer load tap changer. This remote-controlled tap changer feature eliminates the need to manually change a transformer's step-up and step-down taps.

Built-in Thermal Printer (ATRT-03 S2 and ATRT-03A S2 only)

The ATRT-03 S2 and ATRT-03A S2 feature a built-in 4.5-inch wide thermal printer that can print test results. The printer and paper dispenser are mounted under the front panel for protection.

1.2 Technical Specifications

1.2.1. ATRT-03 S2 Technical Specifications

Table 1. ATRT-03 S2 Technical Specifications

TYPE	Portable, lightweight, automatic, 3-phase transformer turns-ratio meter
PHYSICAL SPECIFICATIONS	18"W x 7"H x 15"D (45.7 cm x 17.8 cm x 38.1 cm); Weight: 20 lbs (9.0 kg)
OPERATING VOLTAGE	100 – 240 Vac, 50/60 Hz
MEASUREMENT METHOD	ANSI/IEEE C57.12.90
TURNS-RATIO MEASURING RANGE	0.8 – 15,000
TURNS-RATIO ACCURACY	0.8 – 1,999: ±0.1%, 2,000 – 3,999: ±0.25%. 4,000 – 15,000: ±1% @ 8 Vac 0.8 – 1,999: ±0.1%, 2,000 – 3,999: ±0.20%. 4,000 – 15,000: ±1% @ 40 Vac 0.8 – 1,999: ±0.1%, 2,000 – 3,999: ±0.15%. 4,000 – 15,000: ±1% @ 100 Vac
TEST VOLTAGES	8 Vac @ 1Amp, 40 Vac @ 0.2 Amp, 100 Vac @ 0.1 Amp
EXCITATION CURRENT READING RANGE	0 – 2 Amperes; Accuracy: ±0.1 mA, ±2% of reading (±1 mA)
PHASE-ANGLE MEASUREMENT	0 – 360 Degrees; Accuracy: ±0.2 degree (±1 digit)
DISPLAY	Back-lit LCD screen (64 x 128 dot graphic display); Viewable in bright sunlight and low-light levels
PRINTER	Built-in 4.5-inch wide thermal printer
COMPUTER INTERFACES	One RS-232C port, One USB port
EXTERNAL DATA STORAGE	One USB Flash drive interface port; Up to 999 transformer test records can be stored on a USB Flash drive (not included).
PC SOFTWARE	Windows® XP/Vista-based Transformer Turns-Ratio Analyzer application is included with purchase price
INTERNAL TEST RECORD STORAGE	Can store 112 transformer test records internally. Each record holds the test record header and up to 33 readings per phase. The readings include turns ratio readings, excitation current readings, and nameplate voltages.
INTERNAL TEST PLAN STORAGE	Can store 128 transformer test plans internally. Test plans can be transferred to the unit from the PC via the RS-232C/USB port or via the USB Flash drive interface
LOAD TAP CHANGER CONTACT	240 Vac, 2 Amps
SAFETY	Designed to meet UL 61010A-1 and CAN/CSA C22.2 No. 1010.1-92 standards
ENVIRONMENT	Operating: -10° to 50° C (15° to +122° F); Storage: -30° C to 70° C (-22° to +158° F)
HUMIDITY (MAX)	90% RH @ 40° C (104° F) non-condensing
ALTITUDE (MAX)	2000m (6562 ft) to fully safety specifications
CABLES	One 15-foot Single-phase set, One 15-foot 3-phase set, One 25-foot extension set, One safety ground, One USB, One RS-232C, One LTC cable, cable bag
WARRANTY	One year on parts and labor



NOTE

The above specifications are valid at nominal operating voltage and at a temperature of 25°C (77°F). Specifications may change without prior notice.

1.2.2. ATRT-03A S2 Technical Specifications

Table 2. ATRT-03A S2 Technical Specifications

TYPE	Portable, lightweight, automatic, 3-phase transformer turns-ratio meter
PHYSICAL SPECIFICATIONS	20"W x 7.5"H x 15.5"D (50 cm x 19 cm x 39.6 cm); Weight: 27 lbs (12 kg)
OPERATING VOLTAGE	100 – 240 Vac, 50/60 Hz
BATTERIES	Two lead acid batteries (12V, 2 AH) provide up to 3 hours of operation
MEASUREMENT METHOD	ANSI/IEEE C57.12.90
TURNS-RATIO MEASURING RANGE	0.8 – 15,000
TURNS-RATIO ACCURACY	0.8 – 1,999: ±0.1%, 2,000 – 3,999: ±0.25%. 4,000 – 15,000: ±1% @ 8 Vac 0.8 – 1,999: ±0.1%, 2,000 – 3,999: ±0.20%. 4,000 – 15,000: ±1% @ 40 Vac 0.8 – 1,999: ±0.1%, 2,000 – 3,999: ±0.15%. 4,000 – 15,000: ±1% @ 100 Vac
TEST VOLTAGES	8 Vac @ 350 mA, 40 Vac @ 70 mA, 100 Vac @ 20 mA
EXCITATION CURRENT READING RANGE	0 – 2 Amperes; Accuracy: ±0.1 mA, ±2% of reading (±1 mA)
PHASE-ANGLE MEASUREMENT	0 – 360 degrees; Accuracy: ±0.2 degree (±1 digit)
DISPLAY	Back-lit LCD screen (64 x 128 dot graphic display); Viewable in bright sunlight and low-light levels
PRINTER	Built-in 4.5-inch wide thermal printer
COMPUTER INTERFACES	One RS-232C port, One USB port
EXTERNAL DATA STORAGE	One USB Flash drive interface port; Up to 999 transformer test records can be stored on a USB Flash drive (not included).
PC SOFTWARE	Windows® XP/Vista-based Transformer Turns-Ratio Analyzer application is included with purchase price
INTERNAL TEST RECORD STORAGE	Can store 112 transformer test records internally. Each record holds the test record header and up to 33 readings per phase. The readings include turns ratio readings, excitation current readings, and nameplate voltages.
INTERNAL TEST PLAN STORAGE	The unit can store 128 transformer test plans. Test plans can be transferred to the unit from the PC via the RS-232C/USB port or via the USB Flash drive interface
LOAD TAP CHANGER CONTACT	240 Vac, 1 Amp
SAFETY	Designed to meet UL 61010A-1 and CAN/CSA C22.2 No. 1010.1-92 standards
ENVIRONMENT	Operating: -10° to 50° C (15° to +122° F); Storage: -30° C to 70° C (-22° to +158° F)
HUMIDITY (MAX)	90% RH @ 40° C (104° F) non-condensing
ALTITUDE (MAX)	2000m (6562 ft) to fully safety specifications
CABLES	One 15-foot single-phase set, One 15-foot 3-phase set, one 25-foot extension set, One safety ground, One USB, One RS-232, One LTC cable, cable bag
WARRANTY	One year on parts and labor



NOTE

The above specifications are valid at nominal operating voltage and at a temperature of 25°C (77°F). Specifications may change without prior notice.

1.2.3. ATRT-03B S2 Technical Specifications
Table 3. ATRT-03B S2 Technical Specifications

TYPE	Portable, lightweight, automatic, 3-phase transformer turns-ratio meter
PHYSICAL SPECIFICATIONS	18"W x 7"H x 15"D (45.7 cm x 17.8 cm x 38.1 cm); Weight: 20 lbs (9.0 kg)
OPERATING VOLTAGE	100 – 240 Vac, 50/60 Hz
MEASUREMENT METHOD	ANSI/IEEE C57.12.90
TURNS-RATIO MEASURING RANGE	0.8 – 15,000
TURNS-RATIO ACCURACY	0.8 – 1,999: $\pm 0.1\%$, 2,000 – 3,999: $\pm 0.25\%$. 4,000 – 15,000: $\pm 1\%$ @ 8 Vac 0.8 – 1,999: $\pm 0.1\%$, 2,000 – 3,999: $\pm 0.20\%$. 4,000 – 15,000: $\pm 1\%$ @ 40 Vac 0.8 – 1,999: $\pm 0.1\%$, 2,000 – 3,999: $\pm 0.15\%$. 4,000 – 15,000: $\pm 1\%$ @ 100 Vac
TEST VOLTAGES	8 Vac @ 1Amp, 40 Vac @ 0.2 Amp, 100 Vac @ 0.1 Amp
EXCITATION CURRENT READING RANGE	0 – 2 Amperes; Accuracy: ± 0.1 mA, $\pm 2\%$ of reading (± 1 mA)
PHASE-ANGLE MEASUREMENT	0 – 360 Degrees; Accuracy: ± 0.2 degree (± 1 digit)
DISPLAY	Back-lit LCD screen (64 x 128 dot graphic display); Viewable in bright sunlight and low-light levels
COMPUTER INTERFACES	One RS-232C port, One USB port
EXTERNAL DATA STORAGE	One USB Flash drive interface port; Up to 999 transformer test records can be stored on a USB Flash drive (not included).
PC SOFTWARE	Windows [®] XP/Vista-based Transformer Turns-Ratio Analyzer application is included with purchase price
INTERNAL TEST RECORD STORAGE	Can store 112 transformer test records internally. Each record holds the test record header and up to 33 readings per phase. The readings include turns ratio readings, excitation current readings, and nameplate voltages.
INTERNAL TEST PLAN STORAGE	Can store 128 transformer test plans internally. Test plans can be transferred to the unit from the PC via the RS-232C/USB port or via the USB Flash drive interface
LOAD TAP CHANGER CONTACT	240 Vac, 2 Amps
SAFETY	Designed to meet UL 61010A-1 and CAN/CSA C22.2 No. 1010.1-92 standards
ENVIRONMENT	Operating: -10° to 50° C (15° to $+122^{\circ}$ F); Storage: -30° C to 70° C (-22° to $+158^{\circ}$ F)
HUMIDITY (MAX)	90% RH @ 40° C (104° F) non-condensing
ALTITUDE (MAX)	2000m (6562 ft) to fully safety specifications
CABLES	One 15-foot Single-phase set, One 15-foot 3-phase set, One 25-foot extension set, One safety ground, One USB, One RS-232C, One LTC cable, cable bag
WARRANTY	One year on parts and labor

NOTE

The above specifications are valid at nominal operating voltage and at a temperature of 25°C (77°F). Specifications may change without prior notice.

1.3 Controls and Indicators

The ART-03 S2, ART-03A S2, and ART-03B S2 controls and indicators are shown in Figure 1, Figure 2, and Figure 3, respectively. A leader line with an index number points to each control and indicator, which is cross-referenced to a functional description in the corresponding table. The purpose of the controls and indicators may seem obvious, but users should familiarize themselves with them before using the ART. Accidental misuse of the controls will usually cause no serious harm. Users should also familiarize themselves with the safety summary information found on the front page of this User's Manual.

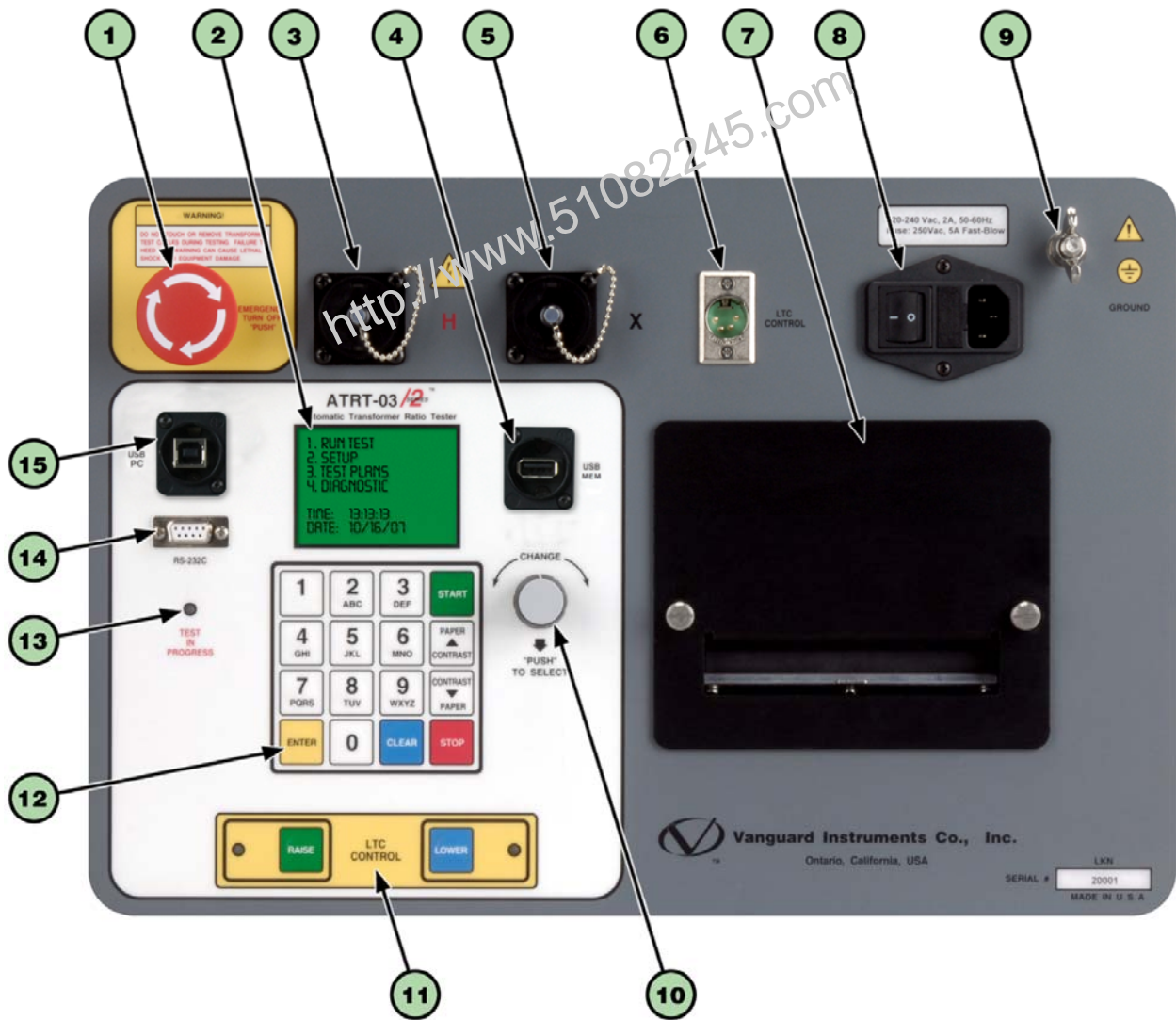

Figure 1. ART-03 S2 Controls and Indicators

Table 4. Functional Descriptions of ATRT-03 S2 Controls and Indicators

Item Number	Panel Markings	Functional Description
1	EMERGENCY TURN OFF "PUSH"	Emergency turn-off test voltage switch.
2		Back-lit LCD screen (62 x 128 dot graphic), viewable in bright sunlight and low-light levels.
3	H	H voltage connector.
4	USB MEM	USB Flash drive interface port.
5	X	X voltage connector.
6	LTC CONTROL	Load Tap Changer controller connector.
7		4.5-inch wide thermal printer.
8	120-240 Vac, 2A, 50-60Hz Fuse: 250Vac, 5A Fast-Blow	Input power connector and fused power switch with third-wire safety ground.
9	GROUND	Ground stud for connecting to sub-station ground.
10	CHANGE "PUSH" TO SELECT	Control knob. You can scroll through menu items by turning the control knob. A highlighted menu item can be selected by pushing the control knob.
11	LTC CONTROL	Load Tap Changer control buttons.
12		Rugged alpha-numeric keypad.
13	TEST IN PROGRESS	This LED flashes in response to commands or when a test voltage is applied to the test transformer.
14	RS-232C	RS-232C PC interface connector.
15	USB PC	USB PC interface connector.

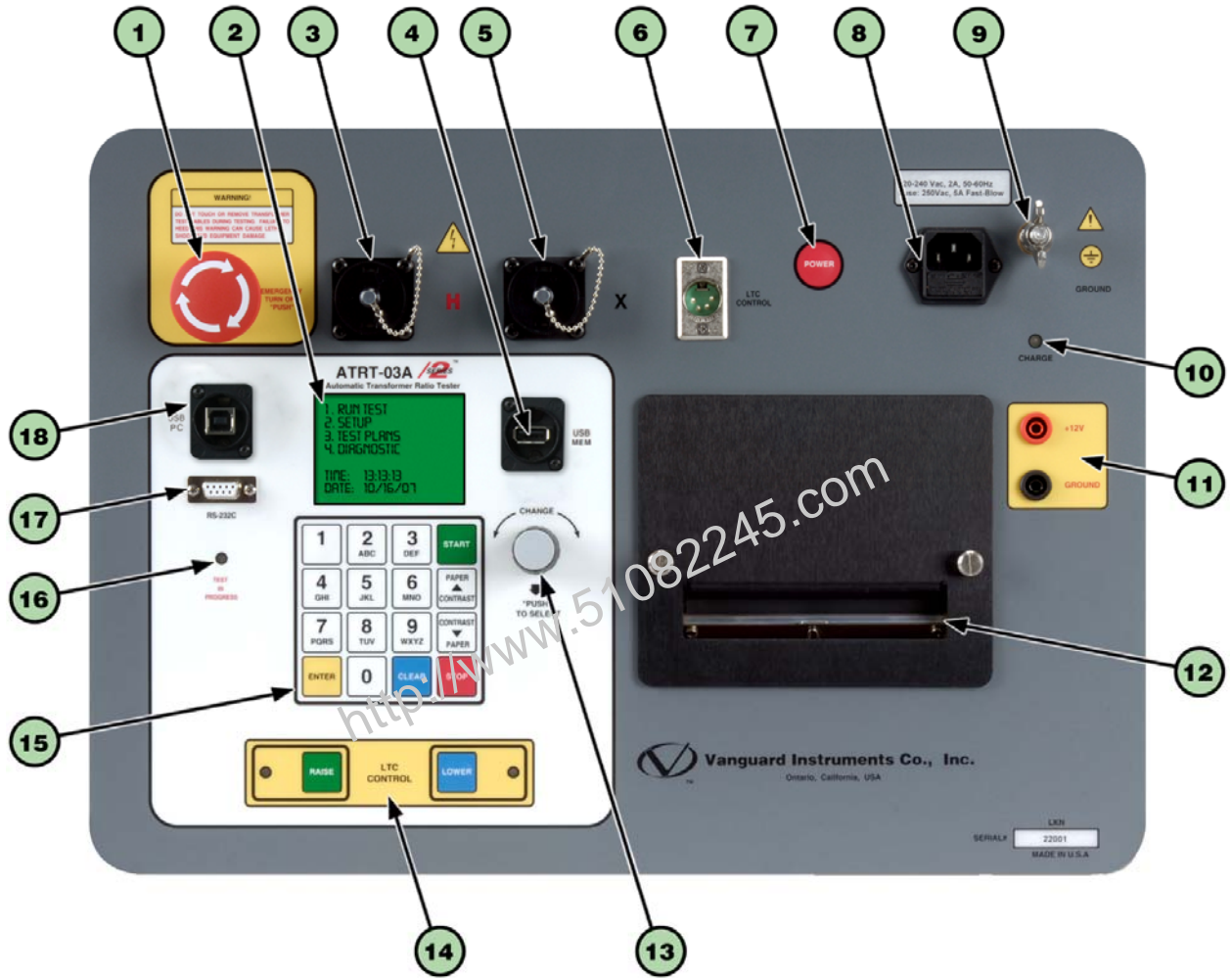

Figure 2. ATRT-03A S2 Controls and Indicators

Table 5. Functional Descriptions of ATRT-03A S2 Controls and Indicators

Item Number	Panel Markings	Functional Description
1	EMERGENCY TURN OFF "PUSH"	Emergency turn off test voltage switch.
2		Back-lit LCD screen (64 x 128 dot graphic), viewable in bright sunlight and low-light levels.
3	H	H voltage connector.
4	USB MEM	USB Flash drive interface port.
5	X	X voltage connector
6	LTC CONTROL	Load Tap Changer controller connector.
7	POWER	Power switch
8	120-240 Vac, 2A, 50-60Hz Fuse: 250Vac, 5A Fast-Blow	Input power connector with third-wire safety ground.
9	GROUND	Ground stud for connecting to sub-station ground.
10	CHARGE	LED is lit when internal batteries are being charged.
11	+12V GROUND	12 VDC input connectors.
12		4.5-inch wide thermal printer.
13	CHANGE "PUSH" TO SELECT	Control knob. You can scroll through menu items by turning the control knob. A highlighted menu item can be selected by pushing the control knob.
14	LTC CONTROL	Load Tap Changer control buttons.
15		Rugged alpha-numeric keypad
16	TEST IN PROGRESS	This LED flashes in response to commands or when a test voltage is applied to the test transformer.
17	RS-232C	RS-232C PC interface connector.
18	USB PC	USB PC interface connector.

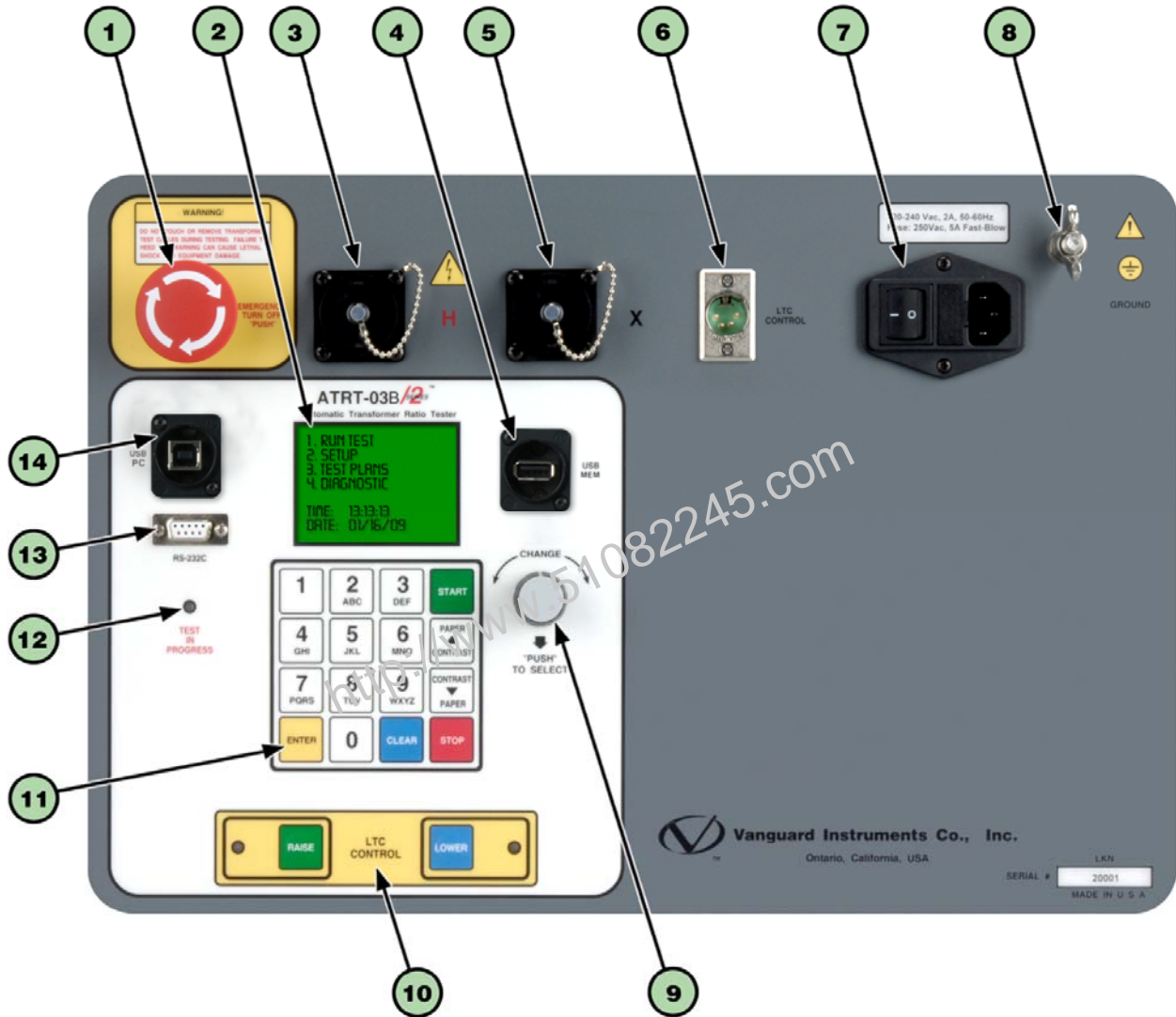

Figure 3. ATRT-03B S2 Controls and Indicators

Table 6. Functional Descriptions of ATRT-03B S2 Controls and Indicators

Item Number	Panel Markings	Functional Description
1	EMERGENCY TURN-OFF "PUSH"	Emergency turn off test voltage switch.
2		Back-lit LCD screen (64 x 128 dot graphic), viewable in bright sunlight and low-light levels.
3	H	H voltage connector.
4	USB MEM	USB Flash drive interface port.
5	X	X voltage connector.
6	LTC CONTROL	Load Tap Changer controller connector.
7	120-240 Vac, 2A, 50-60 Hz Fuse: 250Vac, 5A Fast-Blow	Input power connector and fused power switch with third-wire safety ground.
8	GROUND	Ground stud for connecting to sub-station ground.
9	CHANGE "PUSH" TO SELECT	Control knob. You can scroll through menu items by turning the control knob. A highlighted menu item can be selected by pushing the control knob.
10	LTC CONTRCL	Load Tap Changer control buttons.
11		Rugged alpha-numeric keypad.
12	TEST IN PROGRESS	This LED flashes in response to commands or when a test voltage is applied to the test transformer.
13	RS-232C	RS-232C PC interface connector.
14	USB PC	USB PC interface connector.

2.0 PRE-TEST SETUP

2.1 Operating Voltages

All three ATRT-03 S2 models can be powered by ac line voltage of 100-240 Vac, 50/60 Hz. For greater flexibility, the ATRT-03A S2 features an internal rechargeable lead acid battery and can also be powered by a 12 Vdc external source. The ATRT-03 S2 has built-in ground fault isolation detection and will only operate with voltages that are ground-fault isolated.

2.2 LCD Screen Contrast Control

To increase the LCD screen contrast, press and hold the **[PAPER ^ Contrast]** key for two seconds. Release the button when the desired contrast level has been reached.

To decrease the LCD screen contrast, press and hold the **[PAPER v Contrast]** key for two seconds. Release the button when the desired contrast level has been reached.

2.3 Printer Paper Control

To advance the thermal printer paper, press and release the **[PAPER ^ Contrast]** key.

To retract the thermal printer paper, press and release the **[PAPER v Contrast]** key.

2.4 Printer Paper

The ATRT-03 S2 and ATRT-03A S2's built-in thermal printers use 4.5-inch wide thermal paper for printing test results. To maintain the highest print quality and to avoid paper jams, the use of thermal paper supplied by Vanguard Instruments Company is highly recommended. Additional paper can be ordered from the following sources:

Vanguard Instruments Co, Inc.

1520 S. Hellman Avenue
 Ontario, CA 91761
 Tel: 909-923-9390
 Fax: 909-923-9391
 Part Number: VIC TP-4 paper

BG Instrument Co.

13607 E. Trent Avenue
 Spokane, WA 99216
 Tel: 509-893-9881
 Fax: 509-893-9803
 Part Number: VIC TP-4 paper

2.5 Replacing the Load Tap Changer Controller Fuses

The ATRT-03 S2 features a built-in Load Tap Changer (LTC) controller that can raise or lower the LTC tap position from the front panel. The LTC controller circuit uses two 250 Vac/2A, NO, relay contacts to simulate the LTC Raise/Lower switches. Each relay contact is protected by a 1A/250 Vac fuse (5 X 20mm, fast acting). The fuse should be replaced with a Littlefuse P/N 217001 or equivalent. Follow the instructions below to replace the LTC controller fuses:

- a. Remove the ATRT-03 S2 from its casing by removing the four screws from the bottom of the case:



- b. The LTC control board is located under the left side of the front panel as shown in the figure below. Flip the unit over to easily access the LTC control board fuses.



- c. Replace any fuses as necessary with Littlefuse P/N 217001 or equivalent (250 Vac/1A, 5 X 20mm fast-acting type).
- d. Re-secure the unit in its casing with the screws that were removed in step a.

3.0 OPERATING PROCEDURES

The ATRT-03 S2 should always be grounded with the provided ground cable before connecting H and X cables. The transformer bushings should also be grounded before connecting test leads to the transformer. This will prevent inducing any voltages into the ATRT-03 S2. All transformer bus connections must be removed, and the transformer must be isolated before performing any tests. Typical transformer connection diagrams are illustrated in the sections below.

3.1 Connection Diagrams

3.1.1. Typical Front Panel Connections



Figure 4. Typical Front Panel Cable Connections

3.1.2. Typical Connections to a Load Tap Changer (LTC)

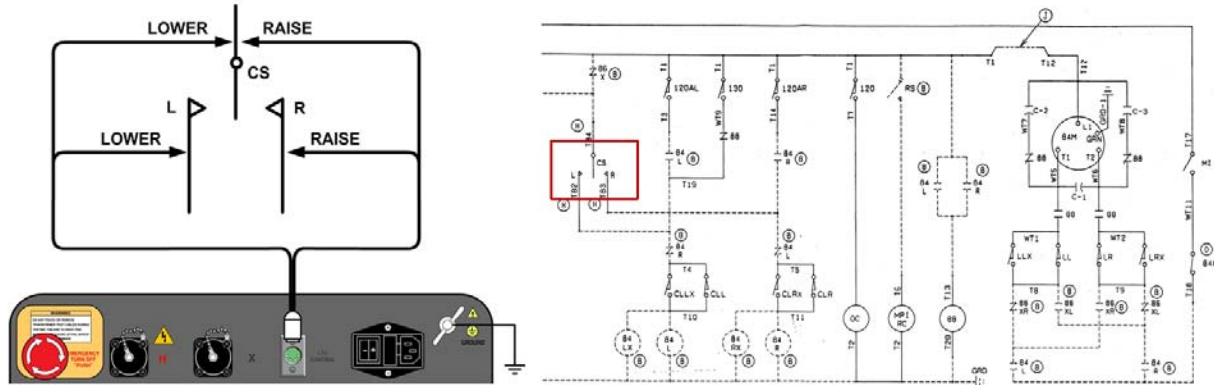

Figure 5. Typical Connections to a Load Tap Changer (LTC)

<http://www.51082245.com>

3.1.3. Typical Connections to a Delta-Wye Transformer

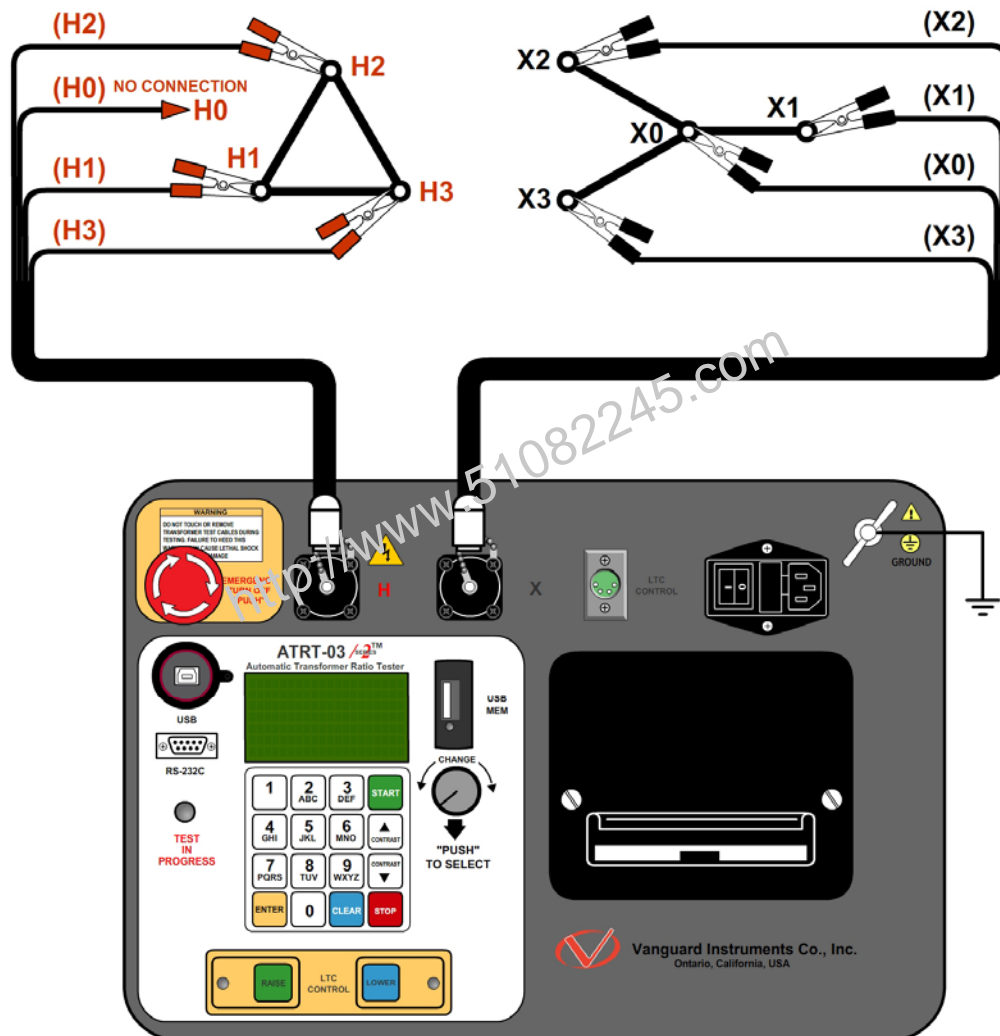

Figure 6. Typical H & X Cable Connections to a Delta-Wye Transformer

3.1.4. Typical Connections to a Single Phase Transformer

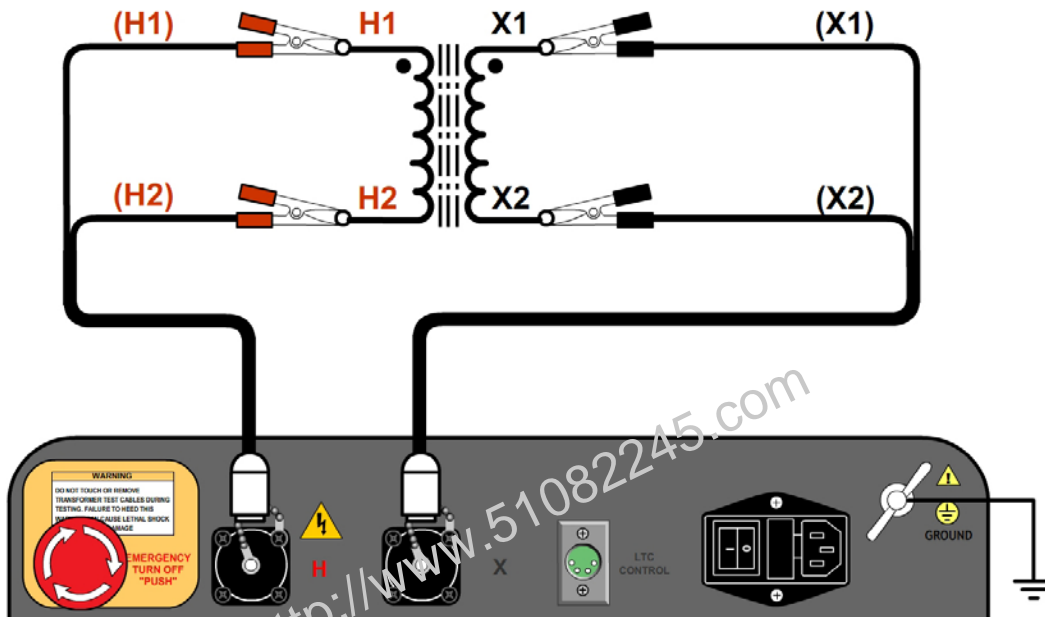

Figure 7. Typical Connections to a Single Phase Transformer

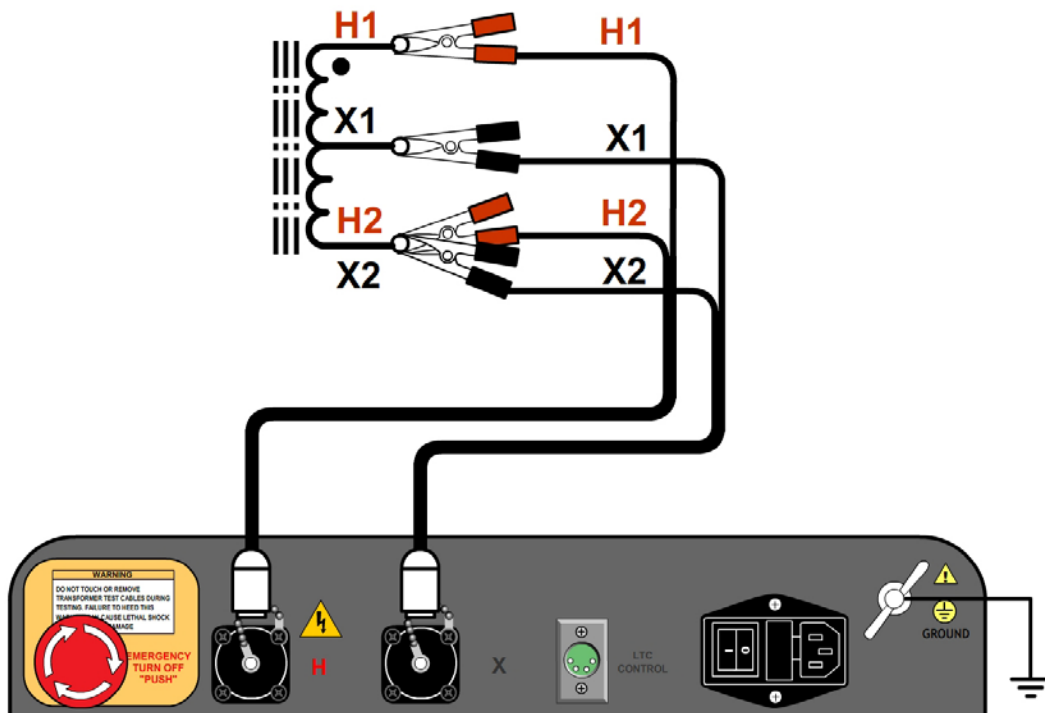

Figure 8. Typical Connections to a Single Phase Auto Transformer

3.1.5. Typical Connections to a Voltage Regulator

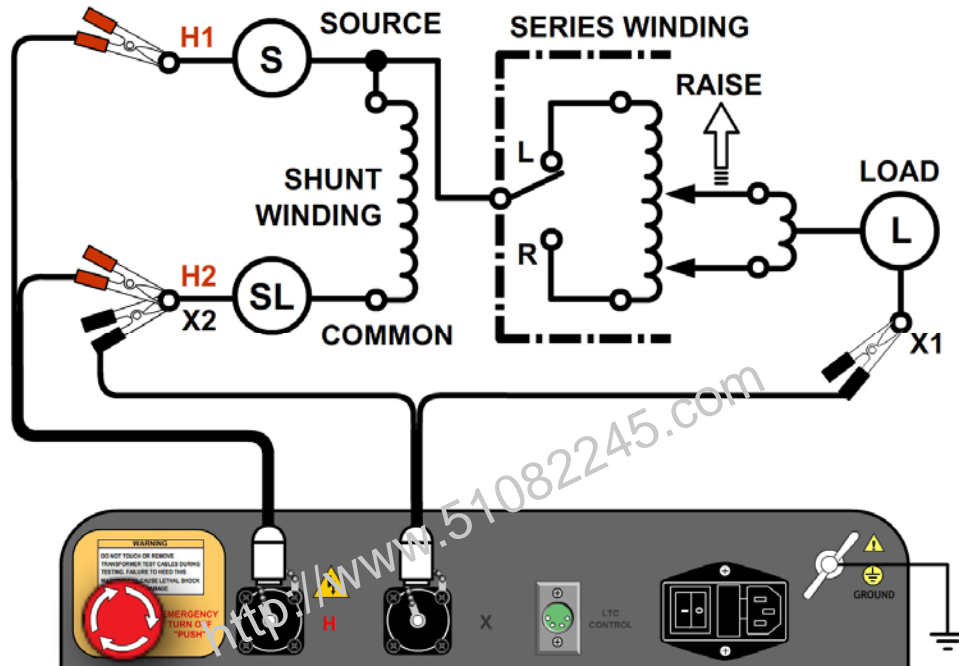

Figure 9. Typical Connections to a Type A Voltage Regulator

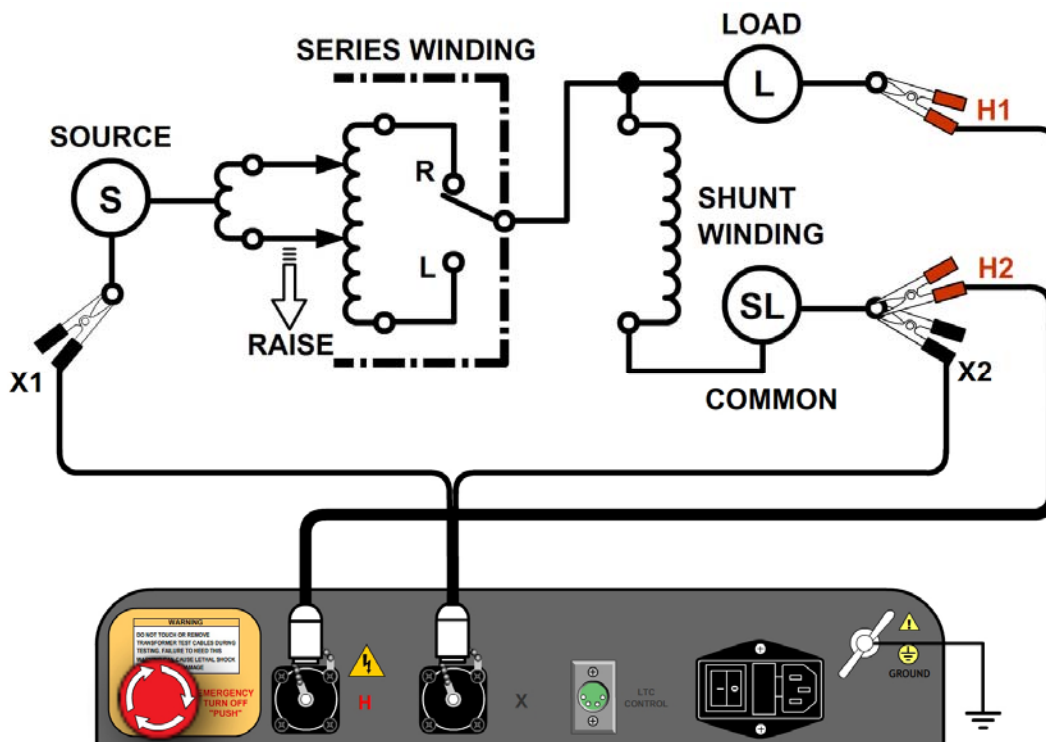

Figure 10. Typical Connections to a Type B Voltage Regulator

3.1.6. Typical Connections to a Donut Type (un-mounted) Current Transformer

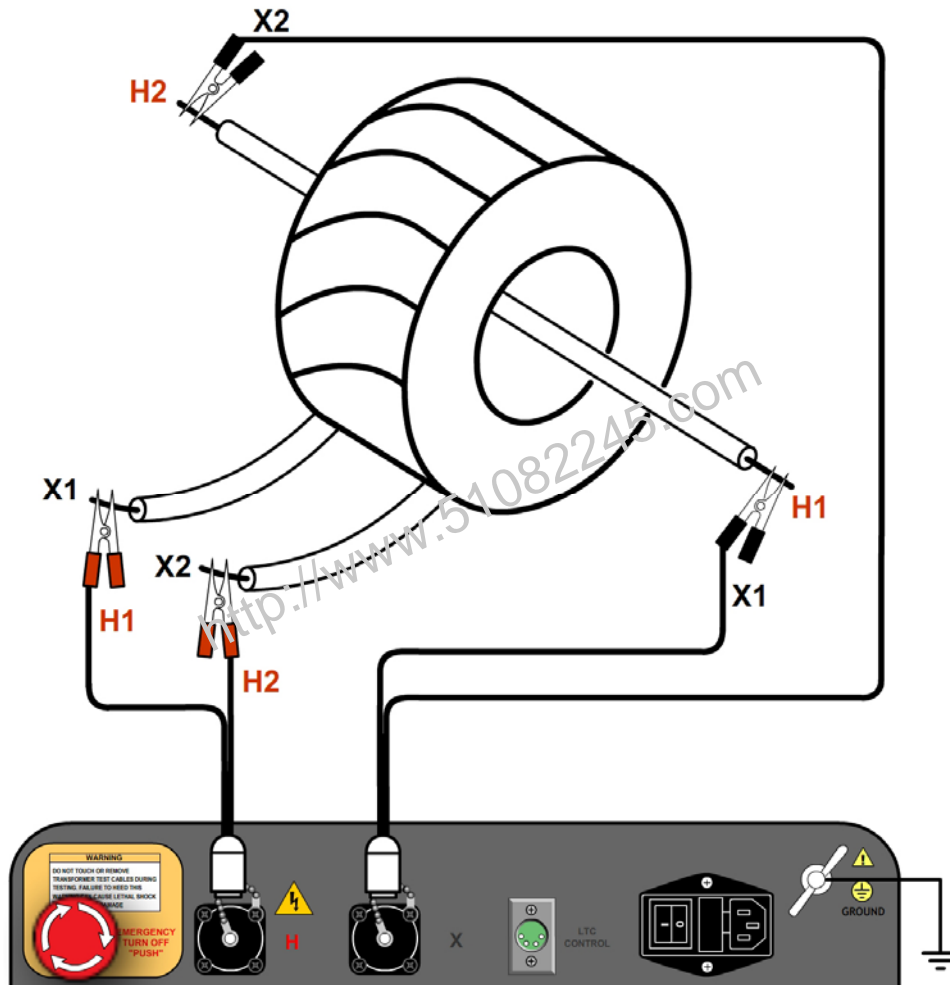

Figure 11. Typical Connections to a Donut Type (un-mounted) Current Transformer (CT)



The H and X test leads are reversed for the CT ratio test connections shown above.

NOTE

3.1.7. Typical Connections to a Multi-Tap Current Transformer

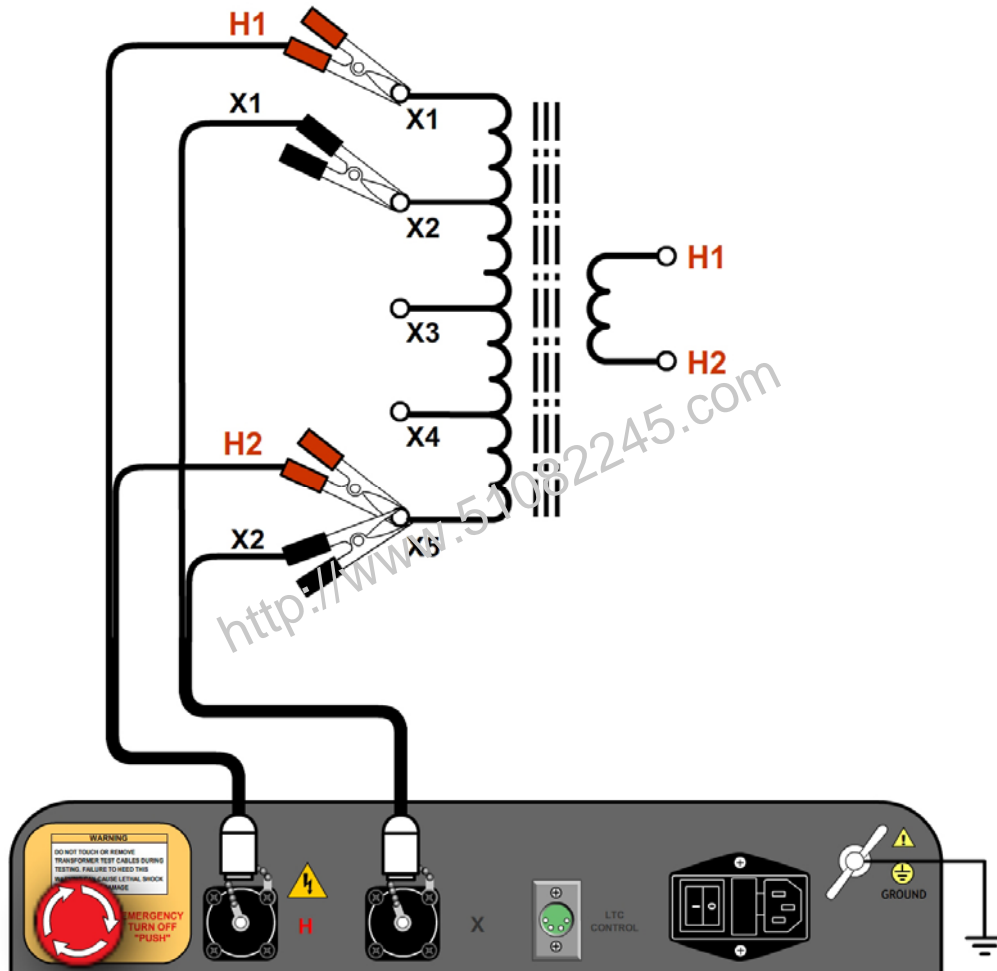

Figure 12. Typical Connections to a Multi-Tap Current Transformer

3.1.8. Typical Connections to a Bushing Mount CT on a Single Phase Transformer

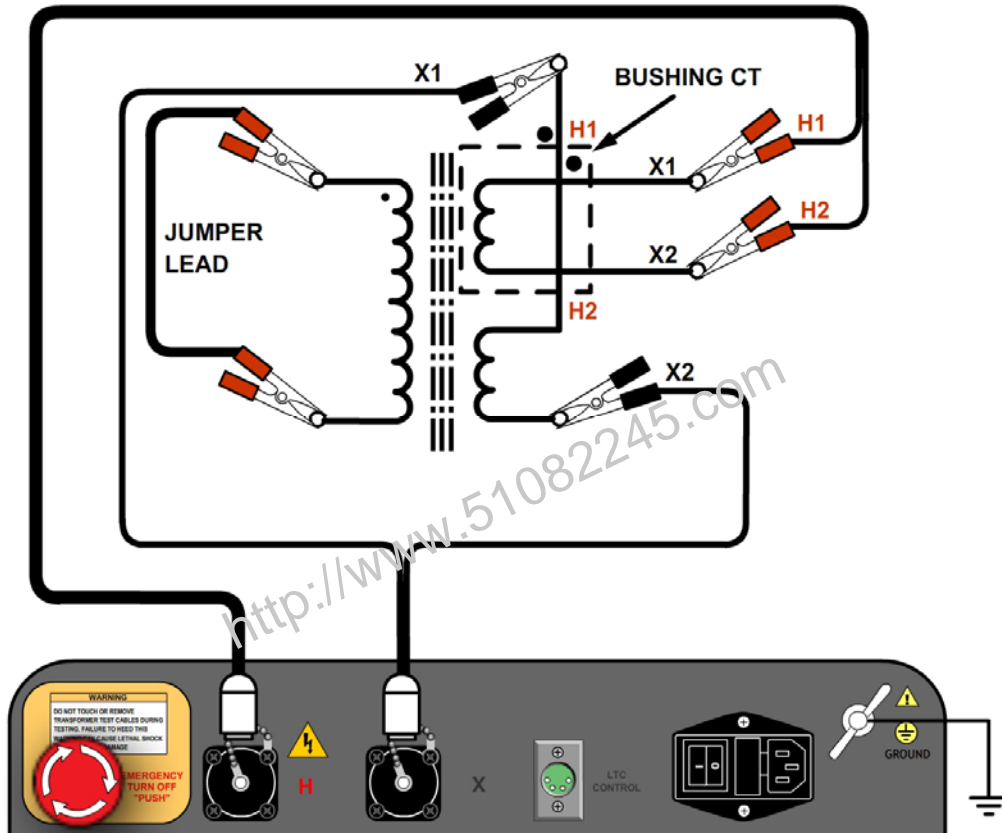

Figure 13. Typical Connections to a Bushing Mount CT on a Single Phase Transformer

3.1.9. Typical Connections to Bushing Mount CT's on Delta Transformer

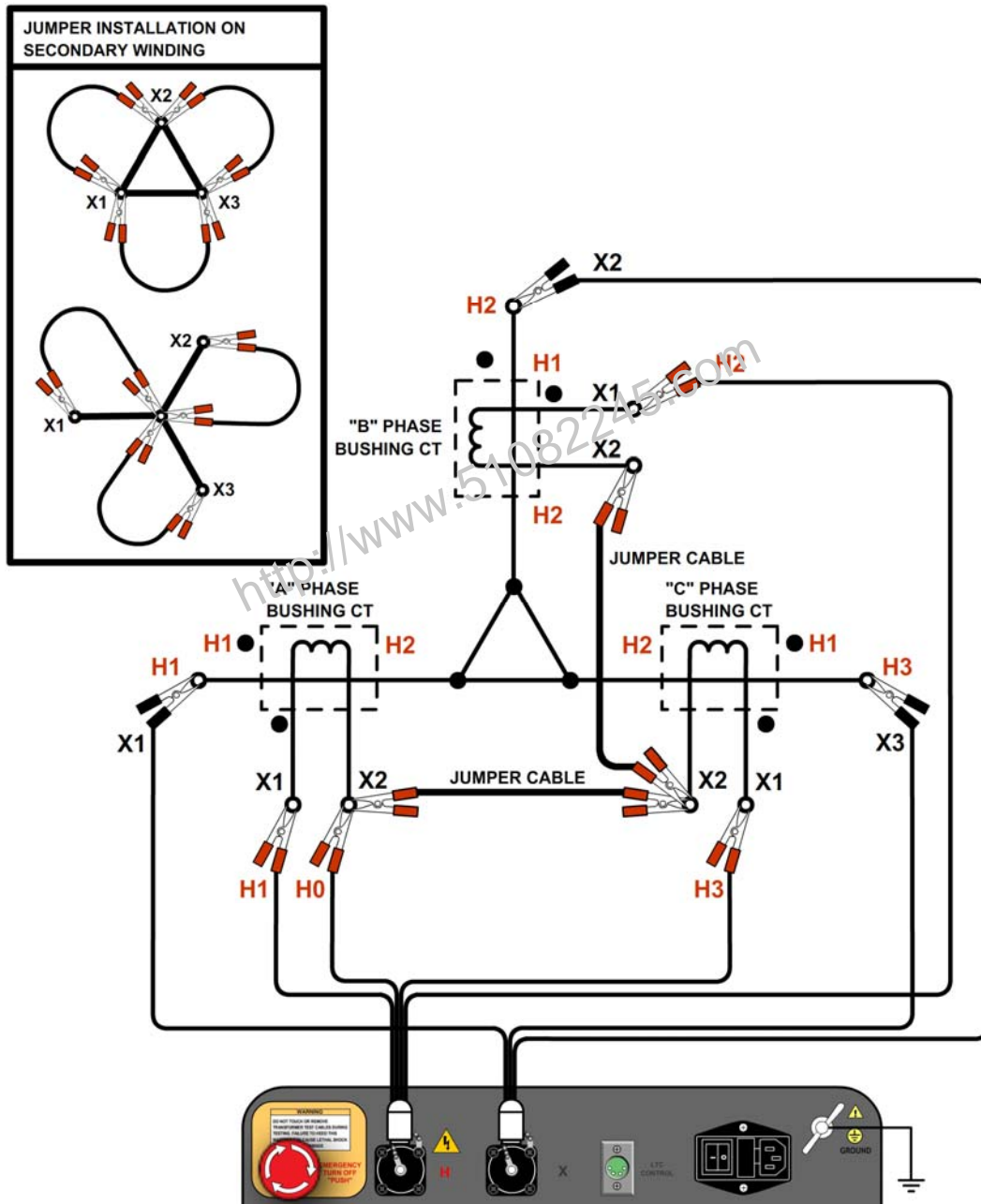

Figure 14. Typical Connections to Bushing Mount CT's on Delta Transformer



The CT turns-ratio is obtained by performing a Ynd11 test.

NOTE

3.1.10. Typical Connections to Bushing Mount CT's on Wye Transformer

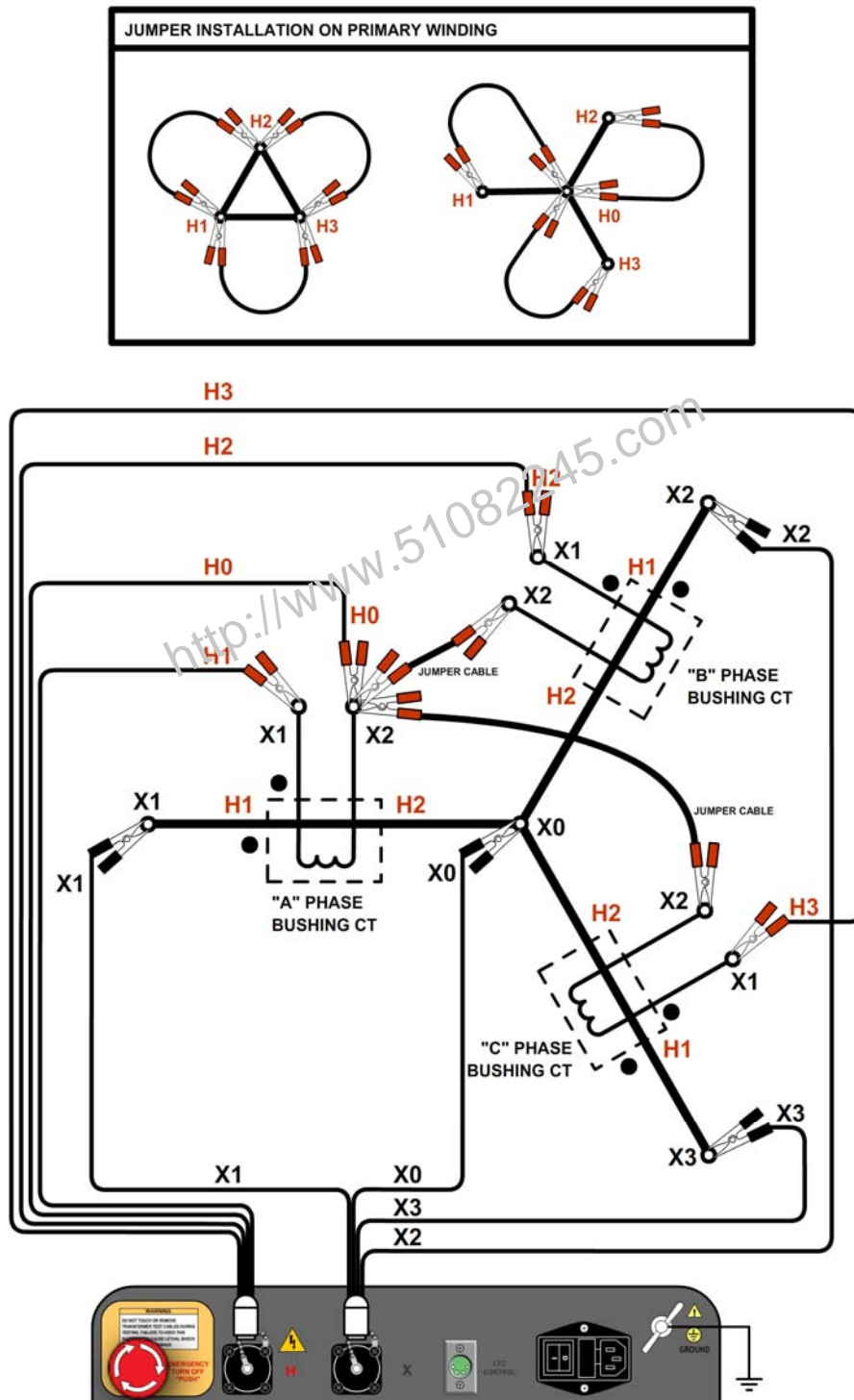

Figure 15. Typical Connections to Bushing Mount CT's on Wye Transformer



The CT turns-ratio is obtained by performing a Ynyn0 test.

NOTE

3.2 Setting the Test Voltage

The ATRT-03 S2 offers three test voltages, 8 Vac, 40 Vac, and 100 Vac. The unit always defaults to 40 Vac at power-on. The 8 Vac test voltage is for testing transformers which require low test voltages, such as metering Current Transformers (CT's). For metering CT's, higher voltages may drive the CT's into saturation, thus giving invalid results. The 40 Vac test voltage is recommended for testing power transformers. The 100 Vac test voltage is recommended for testing power transformers in noisy environments. Follow the steps below to set the test voltage:

- a. Turn on the unit and start from the "START-UP" menu:

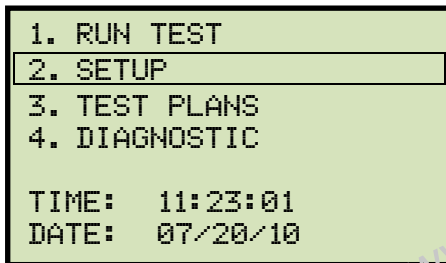

Press the **[2]** key (*SETUP*):



NOTE

You can select menu options by typing the corresponding option number using the alpha-numeric keypad or by using the control knob. To select menu options using the control knob, turn the knob clockwise or counter-clockwise to highlight the next or previous menu item respectively. Once the desired menu option is highlighted, push the control knob to select it.

- b. The following screen will be displayed:

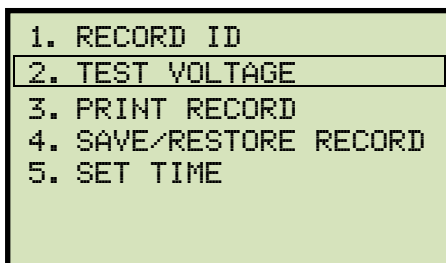

ATRT-03 S2 and ATRT-03A S2

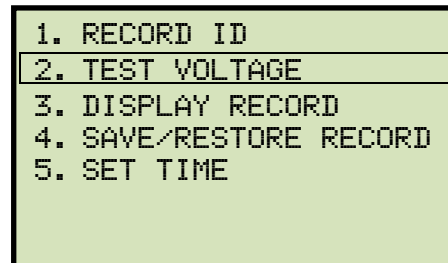

ATRT-03B S2

Press the **[2]** key (*TEST VOLTAGE*).

- c. The following screen will be displayed:

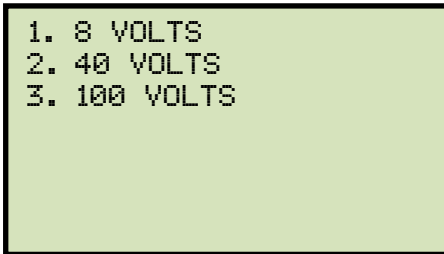

Select the desired test voltage by pressing the corresponding key on the numeric keypad (**[1]**, **[2]**, or **[3]**).

- d. The voltage will be set and the following confirmation message will be displayed:

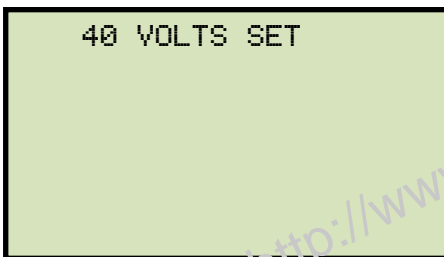

Press any key to return to the "START-UP" menu.

3.3 Setting the Date and Time

To set the date and time:

- a. Start from the "START-UP" menu:

```
1. RUN TEST
2. SETUP
3. TEST PLANS
4. DIAGNOSTIC

TIME: 11:23:01
DATE: 07/20/10
```

Press the **[2]** key (*SETUP*).

- b. The following screen will be displayed:

```
1. RECORD ID
2. TEST VOLTAGE
3. PRINT RECORD
4. SAVE/RESTORE RECORD
5. SET TIME
```

Press the **[5]** key (*SET TIME*).

- c. The following screen will be displayed:

```
ENTER DATE

MM-DD-YY
```

Enter the date using the alpha-numeric keypad.

- d. The following screen will be displayed:

```
ENTER TIME

HH:MM:SS
```

Enter the current time using the alpha-numeric keypad. When the complete time has been entered, you will be immediately returned to the "START-UP" menu.

3.4 Performing Tests

3.4.1. Entering Test Record Header Information

You can enter the test record header information before performing tests. The record header includes identifying information such as the company, station, circuit, manufacturer, etc. Once the header information has been set, it will apply to all subsequent test records. To enter the header information:

- a. Start from the "START-UP" menu:

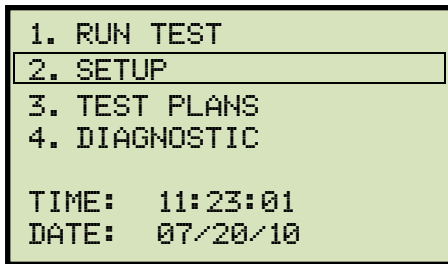

Press the **[2]** key (*SETUP*).

- b. The following screen will be displayed:

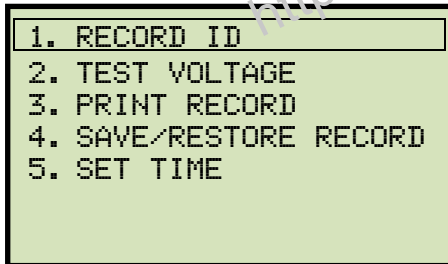

ATRT-03 S2 and ATRT-03A S2

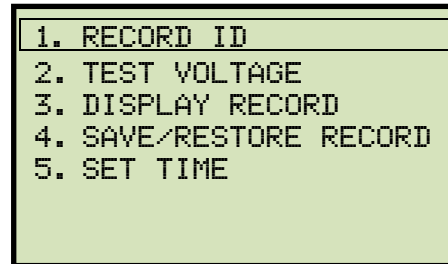

ATRT-03B S2

Press the **[1]** key (*RECORD ID*).

- c. The following screen will be displayed:

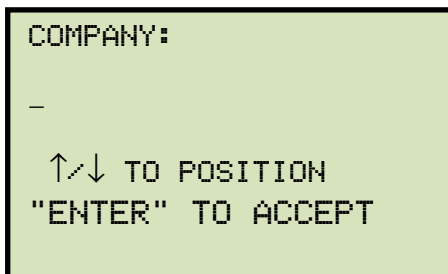

Type the company name using the alpha-numeric keypad.

When pressing a key, the corresponding number on the key will be displayed first. Pressing the key again will display the first letter on the key. Pressing the key again will display the second letter on the key. For example, to type the letter "A", you must press the **[2]** key twice. To erase the character at the cursor position, press the **[CLEAR]** key. Press the **[PAPER ^ Contrast]** key to move to the next character. Press the **[PAPER**

✓ **Contrast]** key to move to the previous character. Press the **[ENTER]** key when you are done typing the company name.

- d. The following screen will be displayed:

```
STATION:  
-  
  
↑/↓ TO POSITION  
"ENTER" TO ACCEPT
```

Type the station name using the alpha-numeric keypad and then press the **[ENTER]** key.

- e. The following screen will be displayed:

```
CIRCUIT:  
-  
  
↑/↓ TO POSITION  
"ENTER" TO ACCEPT
```

Type the circuit information using the alpha-numeric keypad and then press the **[ENTER]** key.

- f. The following screen will be displayed:

```
MANUFACTURER:  
-  
  
↑/↓ TO POSITION  
"ENTER" TO ACCEPT
```

Type the manufacturer name using the alpha-numeric keypad and then press the **[ENTER]** key.

- g. The following screen will be displayed:

```

MODEL:
-
↑/↓ TO POSITION
"ENTER" TO ACCEPT
    
```

Type the transformer's model information using the alpha-numeric keypad and then press the **[ENTER]** key.

- h. The following screen will be displayed:

```

SERIAL NUMBER:
-
↑/↓ TO POSITION
"ENTER" TO ACCEPT
    
```

Type the transformer's serial number using the alpha-numeric keypad and then press the **[ENTER]** key.

- i. The following screen will be displayed:

```

KVA RATING:
-
↑/↓ TO POSITION
"ENTER" TO ACCEPT
    
```

Type the transformer's KVA rating using the alpha-numeric keypad and then press the **[ENTER]** key.

- j. The following screen will be displayed:

```
OPERATOR:
-
↑/↓ TO POSITION
"ENTER" TO ACCEPT
```

Type the operator's name using the alpha-numeric keypad and then press the **[ENTER]** key. All header information will be saved, and you will be returned to the "START-UP" menu.

<http://www.51082245.com>

3.4.2. Testing a Single Phase Transformer

Follow the steps below to test a single phase transformer:

- a. Start from the "START-UP" menu:

```

1. RUN TEST
2. SETUP
3. TEST PLANS
4. DIAGNOSTIC

TIME: 15:45:15
DATE: 07/20/10
    
```

Press the **[1]** key (*RUN TEST*).

- b. The following screen will be displayed:

```

XFMR CONFIG:
1. SINGLE PHASE
2. Dy
3. Yd
4. Dd
5. Yy
6. NEXT PAGE
    
```

Press the **[1]** key (*SINGLE PHASE*).

- c. The following screen will be displayed:

```

NAME PLATE VOLTAGE?
1. YES
2. NO
    
```



If you had entered name plate voltages for a previous test, the following screen will be displayed instead of the above screen:

NOTE

```

NAME PLATE VOLTAGE?
1. YES
2. NO
3. USE PREV DATA
    
```

Press the **[3]** key if you would like to use the name plate voltage values from the previous test performed. **Continue to step d.**

1. YES

Press the **[1]** key (YES) if you would like to enter the transformer name plate voltage values. The following screen will be displayed.

```
NAME PLATE VOLTAGE:
      H : X
      0 :
```

Type the H winding name plate voltage value using the numeric keypad. The screen will be updated as shown below:

```
NAME PLATE VOLTAGE:
      H : X
  2,400 :
```

Press the **[ENTER]** key. The screen will be updated as shown below:

```
NAME PLATE VOLTAGE:
      H : X
  2,400 : 0
```

Type the X winding name plate voltage value using the numeric keypad. The screen will be updated as shown below:

```
NAME PLATE VOLTAGE:
      H : X
  2,400 : 240
```

Press the **[ENTER]** key. **Continue to step d.**

2. NO

Press the **[2]** key (NO) if you do not want to enter the transformer name plate voltage values. **Continue to step d.**

- d. The following screen will be displayed:

```

"START" TO TEST
  OR
"STOP" TO ABORT
    
```

Press the **[START]** key to initiate the test.

- e. The following screen will be displayed while the test is being performed:

```

TEST IN PROGRESS
PLEASE WAIT...
    
```

The test results will be displayed on the LCD screen when testing has finished:

```

RATIO  mA    %DIFF
+10.004 0004  0.04
    
```

The polarity is displayed as either a plus sign (+) for “in-phase” or a minus sign (-) for “out-of-phase”. The value listed under “% DIFF” is the percentage error.



NOTE

The percentage error (% DIFF) is calculated as the absolute value of:
 $[(\text{Calculated Ratio} - \text{Measured Ratio}) / \text{Calculated Ratio}] \times 100$

Press any key to continue.

If using an ATRT-03 S2 or ATRT-03A S2, continue to step f.

If using an ATRT-03B S2, continue to step h.

- f. The following screen will be displayed:

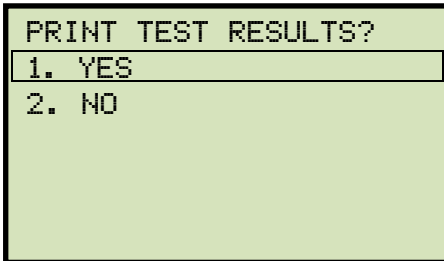

```
PRINT TEST RESULTS?  
1. YES  
2. NO
```

Press the **[1]** key (*YES*) to print the test results.

- g. The following screen will be displayed:

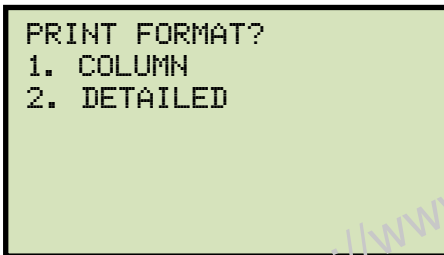

```
PRINT FORMAT?  
1. COLUMN  
2. DETAILED
```

Press the **[1]** key (*COLUMN*) to print a columnar report (see Figure 16) or press the **[2]** key (*DETAILED*) to print a detailed report (see Figure 17).

- h. The following screen will be displayed:

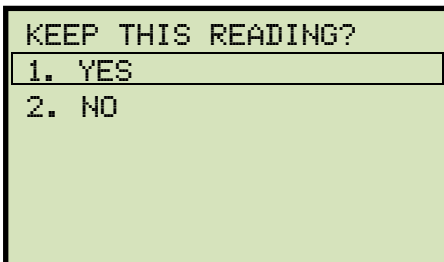

```
KEEP THIS READING?  
1. YES  
2. NO
```

Press the **[1]** key (*YES*) to save the reading.

- i. The following screen will be displayed:

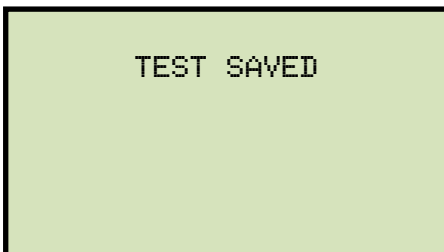

```
TEST SAVED
```

Press any key to continue.



NOTE

The above screen will be displayed if there is currently no data in the unit's memory buffer. If a test was previously performed or a test record was restored from Flash EEPROM or from a Flash drive, the following screen will be displayed instead:

```
PREVIOUS DATA IN BUF
1. APPEND PREV. DATA
2. CLEAR PREV. DATA
```

Press the **[1]** key (*APPEND PREV. DATA*) to append the data in the unit's working memory to the current test results, or press the **[2]** key (*CLEAR PREV. DATA*) to clear any previous data from the unit's memory buffer and only save the current test results.

The following screen will then be displayed:

```
TEST SAVED
```

Press any key to continue.

j. The following screen will be displayed:

```
RUN ANOTHER TEST?
1. YES
2. NO
3. REPEAT PREV. TEST
```

Press the **[2]** key (*NO*).

- k. The following screen will be displayed:

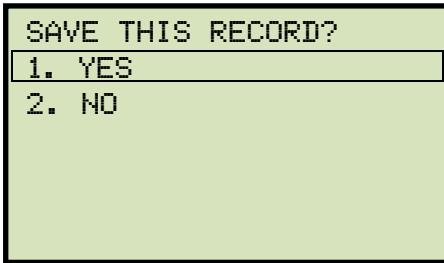

Press the **[1]** key (YES) to save the test record to the unit's Flash EEPROM.

- l. The following screen will be displayed momentarily:

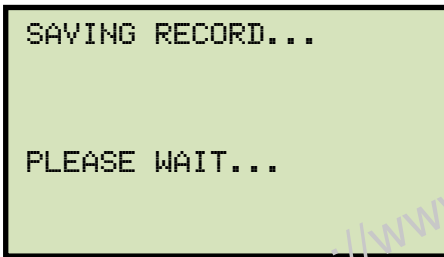

The following confirmation screen will then be displayed:

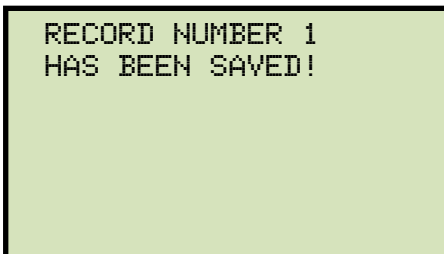

NOTE

The unit will automatically assign the record number and will not over-write existing test records.

Press any key to return to the "START-UP" menu.

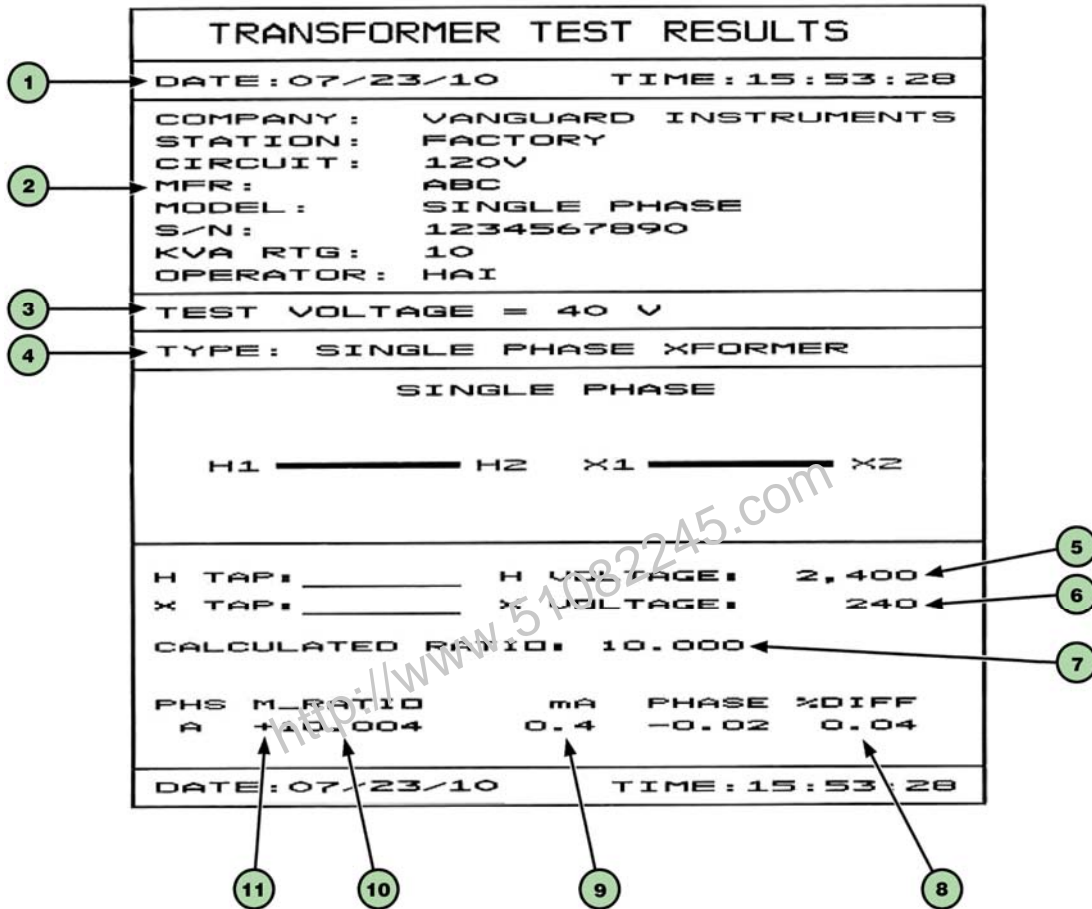

Figure 16. Single Phase Test Results Printout - Column Format (ATRT-03 S2 and ATRT-03A S2 only)

Table 7. Descriptions of Single Phase Test Results Elements (Column Format)

Item Number	Description
1	Test record date and time.
2	Test record header information (see section 3.4.1).
3	Test voltage.
4	Type of transformer under test.
5	H tap voltage.
6	X tap voltage.
7	Calculated ratio.
8	Percentage error between the calculated ratio and the measured ratio.
9	Excitation current.
10	Measured ratio.
11	Winding polarity.

TRANSFORMER TEST RESULTS	
DATE: 07/23/10	TIME: 09:22:02
COMPANY: VANGUARD INSTRUMENTS	
STATION: FACTORY	
CIRCUIT: 120V	
MFR: ABC	
MODEL: SINGLE PHASE XFORMER	
S/N: 1234567890	
KVA RTG: 10	
OPERATOR: HAI	
TEST VOLTAGE = 40 V	
TYPE: SINGLE PHASE XFORMER	
SINGLE PHASE	
H1 ————— H2 X1 ————— X2	
TEST H1-H2 AND X1-X2	
NAME PLATE VOLTAGE:	
H VOLTAGE:	2,400
H TAP SETTING:	
X VOLTAGE:	240
X TAP SETTING:	
CALCULATED RATIO:	10.000
MEASURED RATIO:	10.099
DIFFERENCE:	0.99%
XFMR TURNS RATIO:	10.099
VOLTAGE RATIO:	10.099
MEASURED PHASE-ANGLE:	0.00 DEG
MEASURED CURRENT:	0.4 mA
DATE: 07/23/10	TIME: 09:22:02

Figure 17. Single Phase Test Results Printout - Detailed Format
(ATRT-03 S2 and ATRT-03A S2 only)

Table 8. Descriptions of Single Phase Test Results Elements (Detailed Format)

Item Number	Description
1	Test record date and time.
2	Test record header information (see section 3.4.1).
3	Test voltage.
4	Type of transformer under test.
5	H tap voltage.
6	X tap voltage.
7	Calculated ratio.
8	Measured ratio.
9	Percentage error between the calculated ratio and the measured ratio.
10	Measured transformer turns ratio.
11	Measured voltage ratio.
12	Winding phase angle.
13	Excitation current.

<http://www.51082245.com>

3.4.3. Testing a Dyn1 (12,000 V/208 V) Transformer

Follow the steps below to test a Dyn1 (12,000 V/208 V) transformer:

- a. Start from the "START-UP" menu:

```
1. RUN TEST
2. SETUP
3. TEST PLANS
4. DIAGNOSTIC

TIME: 15:45:15
DATE: 07/20/10
```

Press the **[1]** key (*RUN TEST*).

- b. The following screen will be displayed:

```
XFMR CONFIG:
1. SINGLE PHASE
2. Dy
3. Yd
4. Dd
5. Yy
6. NEXT PAGE
```

Press the **[2]** key (*Dy*).

- c. The following screen will be displayed:

```
X0 ACCESSIBLE?
1. YES
2. NO
```

Press the **[1]** key (*YES*).

d. The following screen will be displayed:

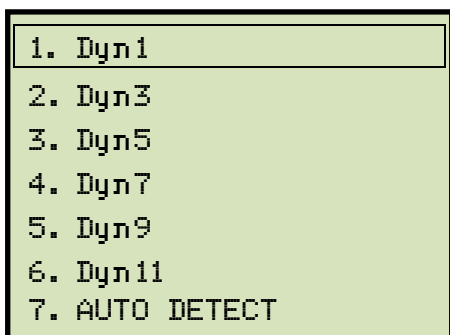

Press the **[1]** key (*Dyn1*).

e. The following screen will be displayed:



1. YES

Press the **[1]** key (*YES*) if you would like to enter the transformer name plate voltage values. The following screen will be displayed.

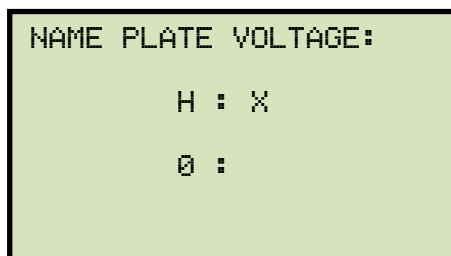

Type the H winding name plate voltage value using the numeric keypad. The screen will be updated as shown below:

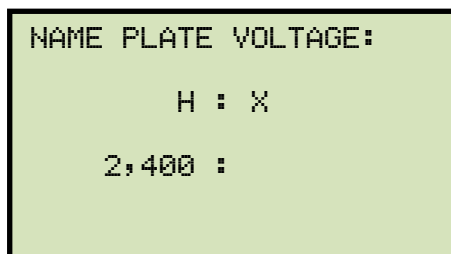

Press the **[ENTER]** key. The screen will be updated as shown below:

```
NAME PLATE VOLTAGE:
      H : X
1,200 : 0
```

Type the X winding name plate voltage value using the numeric keypad. The screen will be updated as shown below:

```
NAME PLATE VOLTAGE:
      H : X
1,200 : 208
```

Press the **[ENTER]** key. **Continue to step f.**

2. *NO*

Press the **[2]** key (*NO*) if you do not want to enter the transformer name plate voltage values. **Continue to step f.**

f. The following screen will be displayed:

```
"START" TO TEST
THREE PHASE OR
"STOP" TO ABORT
```

Press the **[START]** key to initiate the test.

g. The following screen will be displayed while the test is being performed:

```
TEST IN PROGRESS
PLEASE WAIT...
```

The screen will be updated with the Phase A test results as shown:

```

TEST RESULTS:
RATIO  MA    %DIFF
A +100.04 0002  0.11

XFMR TYPE: Dyn1
    
```

Testing will continue, and the screen will be updated with the Phase B test results as shown:

```

TEST RESULTS:
RATIO  MA    %DIFF
A +100.04 0002  0.11
B +100.05 0002  0.12

XFMR TYPE: Dyn1
    
```

Finally, the screen will be updated with the Phase C test results as shown:

```

TEST RESULTS:
RATIO  MA    %DIFF
A +100.04 0002  0.11
B +100.05 0002  0.12
C +100.01 0002  0.09

XFMR TYPE: Dyn1
    
```

Press any key to continue.

If using an ATRT-03 S2 or ATRT-03A S2, continue to step h.

If using an ATRT-03B S2, continue to step j.

h. The following screen will be displayed:

```

PRINT TEST RESULTS?
1. YES
2. NO
    
```

Press the **[1]** key (YES) to print the test results.

- i. The following screen will be displayed:

```
PRINT FORMAT?
1. COLUMN
2. DETAILED
```

Press the **[1]** key (*COLUMN*) to print a columnar report (see Figure 18) or press the **[2]** key (*DETAILED*) to print a detailed report (see Figure 19).

- j. The following screen will be displayed:

```
KEEP THIS READING?
1. YES
2. NO
```

Press the **[1]** key (*YES*) to save the reading.

- k. The following screen will be displayed:

```
TEST SAVED
```

Press any key to continue.

- l. The following screen will be displayed:

```
RUN ANOTHER TEST?
1. YES
2. NO
3. REPEAT PREV. TEST
```

Press the **[2]** key (*NO*).

m. The following screen will be displayed:

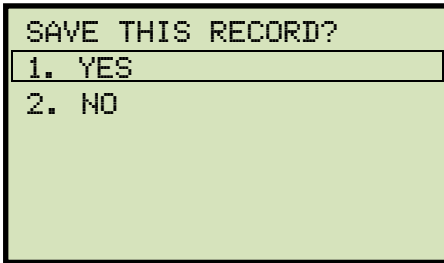

Press the **[1]** key (YES) to save the test record to the unit's Flash EEPROM.

n. The following screen will be displayed momentarily:

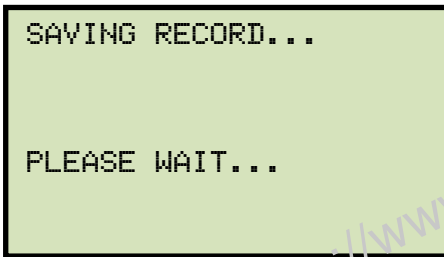

The following confirmation screen will then be displayed:

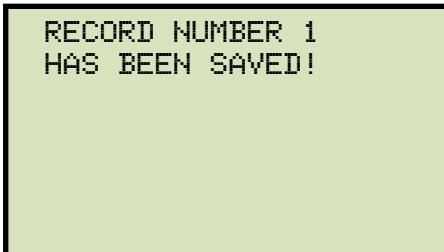

Press any key to return to the "START-UP" menu.

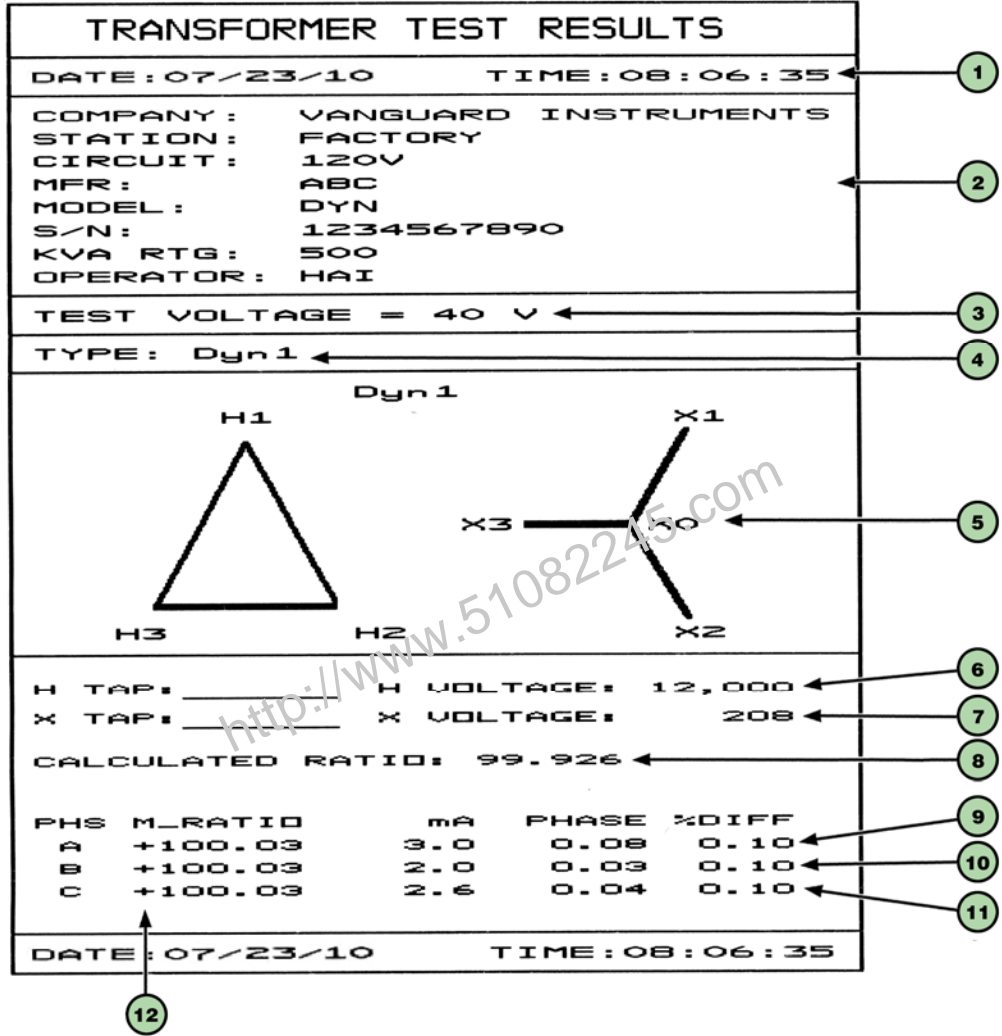

Figure 18. Dyn1 Test Results Printout - Column Format
 (ATRT-03 S2 and ATRT-03A S2 only)

Table 9. Descriptions of Dyn1 Test Results Elements (Column Format)

Item Number	Description
1	Test record date and time.
2	Test record header information (see section 3.4.1).
3	Test voltage.
4	Type of transformer under test.
5	Transformer configuration diagrams (H and X).
6	H tap voltage.
7	X tap voltage.
8	Calculated ratio.
9	Measured ratio, excitation current, phase angle, and percentage error for Phase A.
10	Measured ratio, excitation current, phase angle, and percentage error for Phase B.
11	Measured ratio, excitation current, phase angle, and percentage error for Phase C.
12	Winding polarity.

<http://www.51082245.com>

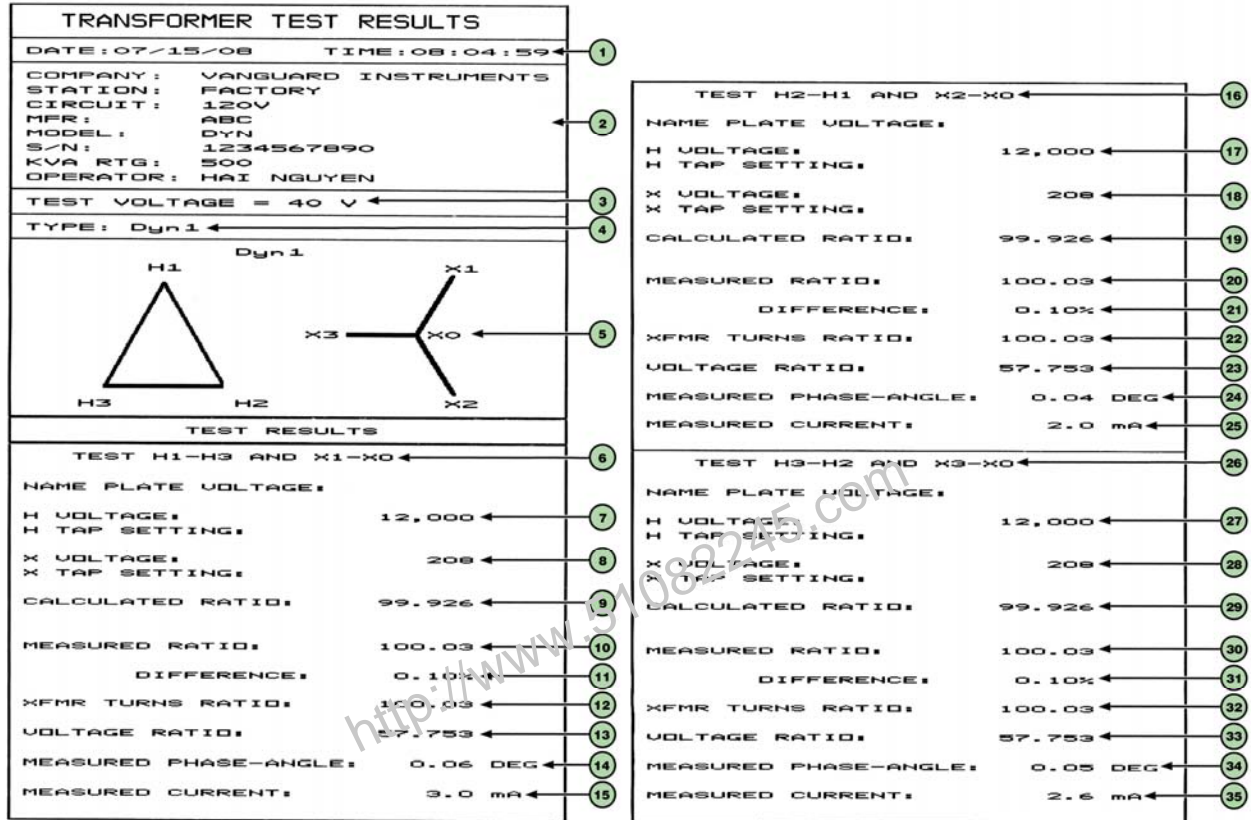

Figure 19. Dyn1 Test Results Printout - Detailed Format
(ATRT-03 S2 and ATRT-03 S2A only)

Table 10. Descriptions of Dyn1 Test Results Elements (Detailed Format)

Item Number	Description
1	Test record date and time.
2	Test record header information (see section 3.4.1).
3	Test voltage.
4	Type of transformer under test.
5	Transformer configuration diagrams.
6	Test H1-H3 and X1-X0 section heading.
7	H1-H3 tap voltage.
8	X1-X0 tap voltage.
9	H1-H3, X1-X0 calculated ratio.
10	H1-H3, X1-X0 measured ratio.
11	H1-H3, X1-X0 percentage error between calculated ratio and measured ratio.
12	H1-H3, X1-X0 transformer turns ratio.
13	H1-H3, X1-X0 voltage ratio.
14	H1-H3, X1-X0 measured phase angle.
15	H1-H3, X1-X0 measured excitation current.
16	Test H2-H1 and X2-X0 section heading.
17	H2-H1 tap voltage.
18	X2-X0 tap voltage.
19	H2-H1, X2-X0 calculated ratio.
20	H2-H1, X2-X0 measured ratio.
21	H2-H1, X2-X0 percentage error between calculated ratio and measured ratio.
22	H2-H1, X2-X0 transformer turns ratio.
23	H2-H1, X2-X0 voltage ratio.
24	H2-H1, X2-X0 measured phase angle.
25	H2-H1, X2-X0 measured excitation current.
26	Test H3-H2 and X3-X0 section heading.
27	H3-H2 tap voltage.
28	X3-X0 tap voltage.
29	H3-H2, X3-X0 calculated ratio.
30	H3-H2, X3-X0 measured ratio.
31	H3-H2, X3-X0 percentage error between calculated ratio and measured ratio.
32	H3-H2, X3-X0 transformer turns ratio.
33	H3-H2, X3-X0 voltage ratio.
34	H3-H2, X3-X0 measured phase angle.
35	H3-H2, X3-X0 measured excitation current.

3.4.4. Testing a Three Phase Transformer Using Auto Detect Mode

The ATRT-03 S2 provides a convenient Auto Detect mode that can automatically detect 130 specific vector groups for different transformer types defined by ANSI, CEI/IEC, and Australian standards. The transformer configurations supported are listed in Appendix A. The ATRT-03 S2 can detect the vector diagrams for Delta-Delta, Wye-Wye, Delta-Wye, and Wye-Delta transformer types. Follow the steps below to test a three phase transformer using auto detect mode:

- a. Start from the "START-UP" menu:

```
1. RUN TEST
2. SETUP
3. TEST PLANS
4. DIAGNOSTIC

TIME: 15:45:15
DATE: 07/20/10
```

Press the **[1]** key (*RUN TEST*).

- b. The following screen will be displayed:

```
XFMR CONFIG:
1. SINGLE PHASE
2. Dy
3. Yd
4. Dd
5. Yy
6. NEXT PAGE
```

Select a supported three phase transformer test by pressing the corresponding numeric key on the keypad (**[2]**, **[3]**, **[4]**, or **[5]**). For this example, we will perform a Yd test (option 3).

- c. The following screen will be displayed:

```
H0 ACCESSIBLE?
1. YES
2. NO
```

Press the **[1]** key (*YES*).

d. The following screen will be displayed:

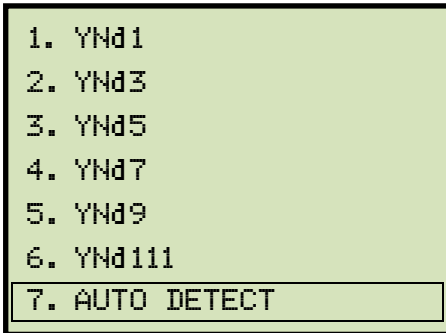

Press the **[7]** key (*AUTO DETECT*).

e. The following screen will be displayed:



1. YES

Press the **[1]** key (*YES*) if you would like to enter the transformer name plate voltage values. The following screen will be displayed.

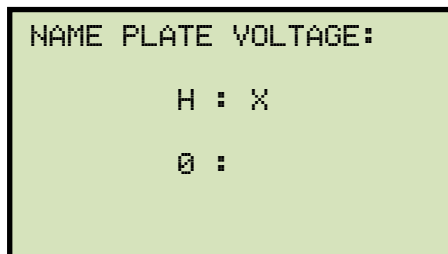

Type the H winding name plate voltage value using the numeric keypad. The screen will be updated as shown below:

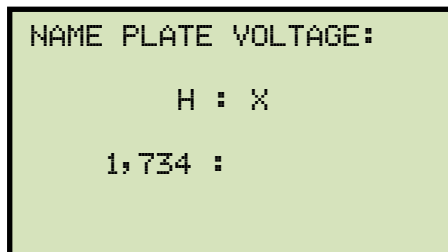

Press the **[ENTER]** key. The screen will be updated as shown below:

```

NAME PLATE VOLTAGE:

      H : X

1,734 : 0
  
```

Type the X winding name plate voltage value using the numeric keypad. The screen will be updated as shown below:

```

NAME PLATE VOLTAGE:

      H : X

1,734 : 100
  
```

Press the **[ENTER]** key. **Continue to step f.**

2. *NO*

Press the **[2]** key (*NO*) if you do not want to enter the transformer name plate voltage values. **Continue to step f.**

f. The following screen will be displayed:

```

"START" TO TEST
THREE PHASE OR
"STOP" TO ABORT
  
```

Press the **[START]** key to initiate the test.

g. The following screen will be displayed while the unit determines the transformer configuration:

```

YND AUTO DETECT

TESTING YND1
  
```

The ATRT-03 S2 will start testing the transformer configurations starting with YNd1. If the transformer is not a type YNd1, it will continue to test for the next type (YNd3, YNd5, etc.) until the transformer type has been determined. The screen will be updated as shown below to indicate which configuration is currently being tested for:

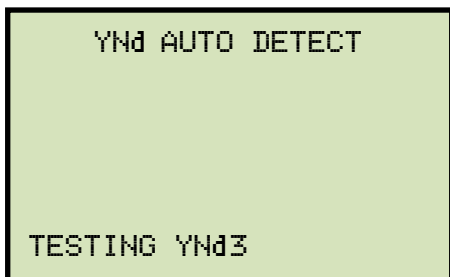

Once the transformer type has been determined, the unit will start performing the test.

- h. The screen will be updated with the Phase A test results as shown:

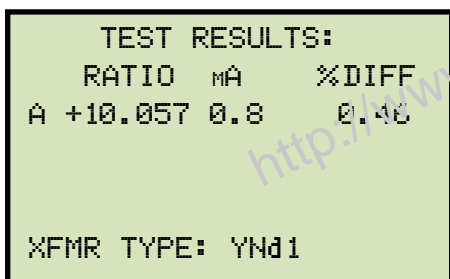

Testing will continue, and the screen will be updated with the Phase B test results as shown:

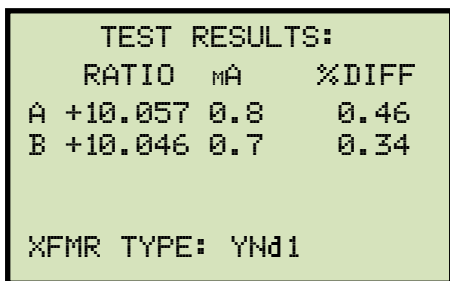

Finally, the screen will be updated with the Phase C test results as shown:

TEST RESULTS:		
RATIO	MA	%DIFF
A +10.057	0.8	0.46
B +10.046	0.7	0.34
C +10.057	0.8	0.46
XFMR TYPE: YNd1		

Press any key to continue.

If using an ATRT-03 S2 or ATRT-03A S2, continue to step i.

If using an ATRT-03B S2, continue to step k.

- i. The following screen will be displayed:

PRINT TEST RESULTS?
1. YES
2. NO

Press the **[1]** key (*YES*) to print the test results.

- j. The following screen will be displayed:

PRINT FORMAT?
1. COLUMN
2. DETAILED

Press the **[1]** key (*COLUMN*) to print a columnar report or press the **[2]** key (*DETAILED*) to print a detailed report.

- k. The following screen will be displayed:

KEEP THIS READING?
1. YES
2. NO

Press the **[1]** key (*YES*) to save the reading.

- l. The following screen will be displayed:

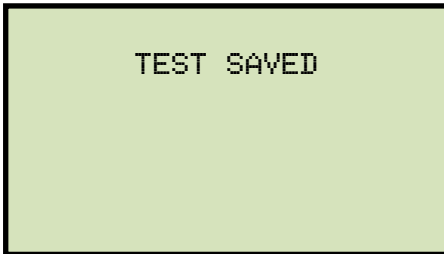

Press any key to continue.

- m. The following screen will be displayed:

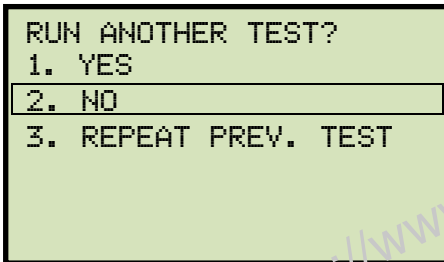

Press the **[2]** key (NO).

- n. The following screen will be displayed:

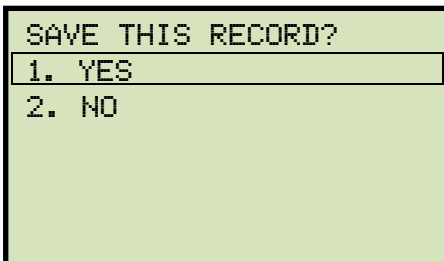

Press the **[1]** key (YES) to save the test record to the unit's Flash EEPROM.

- o. The following screen will be displayed momentarily:

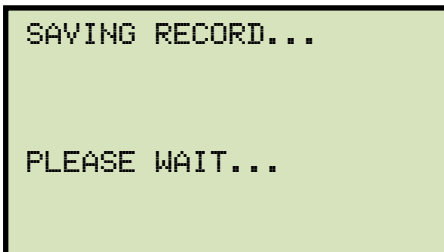

The following confirmation screen will then be displayed:

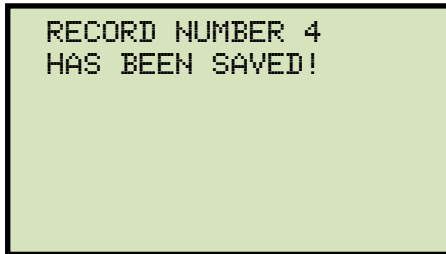

Press any key to return to the "START-UP" menu.

<http://www.51082245.com>

3.5 Working With Test Records

3.5.1. Saving Test Results to a Test Record

After performing a test, the user is presented the option to save the test results to the unit's Flash EEPROM or to a USB Flash Drive. If the test results are not saved immediately after performing a test, they will still remain in the working memory and can be saved later, as long as a new test has not been performed and the unit has not been turned off. Follow the steps below to save the test results from the working memory to a test record (the following procedure can also be used to re-save a restored test record to a new memory location or to a USB Flash Drive):

- a. Perform a test or restore a test record to the working memory (see section 3.5.2 and 3.5.3), and then start from the "START-UP" menu:

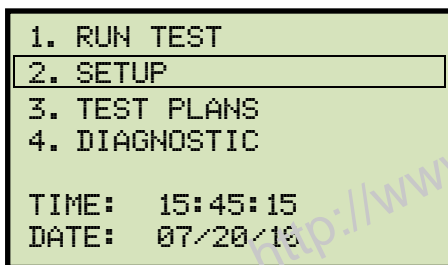

Press the **[2]** key (*SETUP*).

- b. The following screen will be displayed:

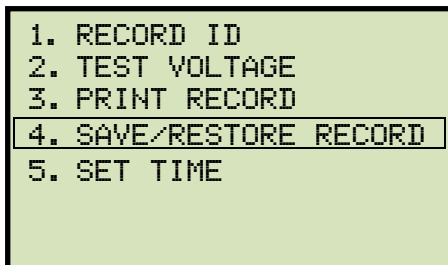

ATRT-03 S2 and ATRT-03A S2

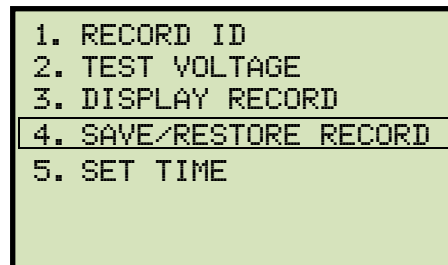

ATRT-03B S2

Press the **[4]** key (*SAVE/RESTORE RECORD*).

- c. The following screen will be displayed:

```
1. RESTORE RECORD
2. SAVE RECORD
3. RECORD DIRECTORY
4. ERASE RECORD
```

Press the **[2]** key (*SAVE RECORD*).

If a USB Flash drive is connected to the unit, continue to step d.

If a USB Flash drive is NOT connected to the unit, continue to step e.

- d. The following screen will be displayed:

```
1. SAVE INTERNALLY
2. SAVE TO THUMB DRIVE
```

1. *SAVE INTERNALLY*

Press the **[1]** key (*SAVE INTERNALLY*) to save the test record to the unit's Flash EEPROM. **Continue to step e.**

2. *SAVE TO THUMB DRIVE*

Press the **[2]** key (*SAVE TO THUMB DRIVE*) to save the test record to the connected USB Flash drive. The following screen will be displayed:

```
REC_001 SAVED TO
THUMB DRIVE.
```

Press any key to return to the "START-UP" menu.

- e. The following screen will be displayed:

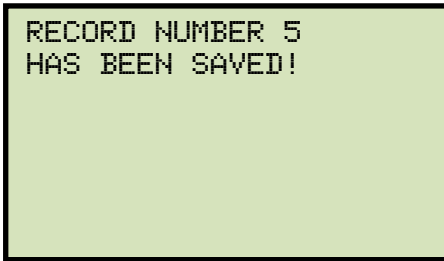

```
RECORD NUMBER 5
HAS BEEN SAVED!
```

Press any key to return to the "START-UP" menu.

<http://www.51082245.com>

3.5.2. Restoring a Test Record From Flash EEPROM

Use the steps below to restore a test record from the ATRT-03 S2's Flash EEPROM to the working memory:

- a. Start from the "START-UP" menu:

```

1. RUN TEST
2. SETUP
3. TEST PLANS
4. DIAGNOSTIC

TIME: 15:45:15
DATE: 07/20/10

```

Press the **[2]** key (*SETUP*).

- b. The following screen will be displayed:

```

1. RECORD ID
2. TEST VOLTAGE
3. PRINT RECORD
4. SAVE/RESTORE RECORD
5. SET TIME

```

ATRT-03 S2 and ATRT-03A S2

```

1. RECORD ID
2. TEST VOLTAGE
3. DISPLAY RECORD
4. SAVE/RESTORE RECORD
5. SET TIME

```

ATRT-03B S2

Press the **[4]** key (*SAVE/RESTORE RECORD*).

- c. The following screen will be displayed:

```

1. RESTORE RECORD
2. SAVE RECORD
3. RECORD DIRECTORY
4. ERASE RECORD

```

Press the **[1]** key (*RESTORE RECORD*).

d. The following screen will be displayed:

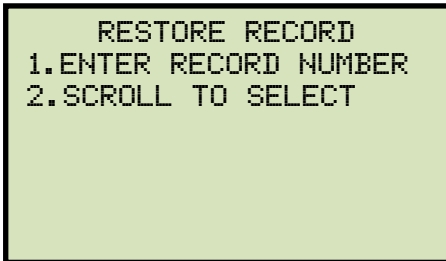

If you have a USB Flash drive inserted in the ATRT-03 S2's "USB MEM" port, the following screen will be displayed instead of the above screen:

NOTE

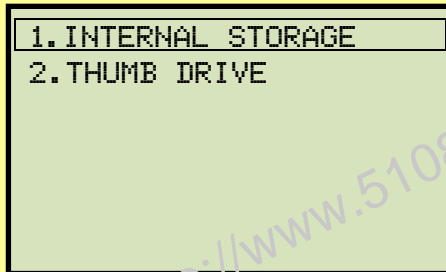

Press the **[1]** key (*INTERNAL STORAGE*).

The following screen will be displayed:

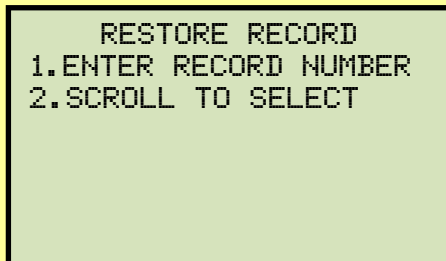

Continue with the steps below.

1. *ENTER RECORD NUMBER*

Press the **[1]** key (*ENTER RECORD NUMBER*) if you know the record number that you would like to restore.

1.1. The following screen will be displayed:



Type the record number using the alpha-numeric keypad and then press the **[ENTER]** key.

- 1.2. The following screen will be displayed:

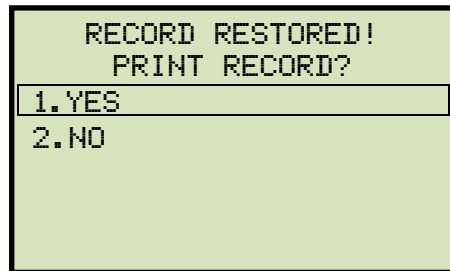

Press the **[1]** key (*YES*) to print the test record.

If using an ATRT-03 S2 or ATRT-03A S2, continue to step 1.3.

If using an ATRT-03B S2, continue to step 1.4.

- 1.3. The following screen will be displayed:

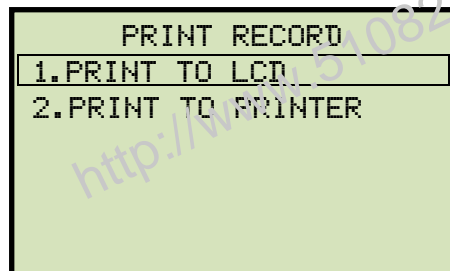

Press the **[1]** key (*PRINT TO LCD*) to display the restored test record data on the unit's LCD screen. **Continue to step 1.4.**

Press the **[2]** key (*PRINT TO PRINTER*) to print the restored test record data on the unit's built-in thermal printer. The following screen will be displayed:

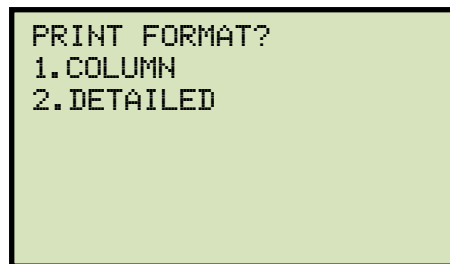

Press the **[1]** key (*COLUMN*) to print the test report in columnar format, or press the **[2]** key (*DETAILED*) to print the test report in detailed format.

The test report will be printed, and you will be returned to the "START-UP" menu. The restored test record will remain loaded in the working memory.

- 1.4. The basic information about the restored test record will be displayed as shown:

```

YNd1
NUM TESTS: 1
07/22/10 07:52:50
    
```

Press the **[PAPER ∨ Contrast]** key. The test record details will be displayed as shown:

```

1  YNd1
  8 VOLTS

  RATIO  mA  %DIFF
A +10.057 0.8  0.46
B +10.046 0.7  0.34
C +10.057 0.8  0.46
    
```

Press the **[STOP]** key to return to the “START-UP” menu. The restored test record will remain loaded in the working memory.

2. *SCROLL TO SELECT*

Press the **[2]** key (*SCROLL TO SELECT*) to scroll through a directory of the stored test records.

- 2.1. The following screen will be displayed:

```

RECORDS DIRECTORY

"UP" TO SCROLL FWD
"DWN" TO SCROLL RVS
    
```

Press the **[PAPER ^ Contrast]** button or the **[PAPER ∨ Contrast]** key to display the next or previous test record, respectively.

The basic test record information will be displayed as shown:

```
#1      07/21/10 09:05  
SINGLE PHASE  
1 TESTS
```

When you have located the test record that you would like to restored, press the **[ENTER]** key. **Continue to step 1.2 on page 64.**

<http://www.51082245.com>

3.5.3. Restoring a Test Record From a USB Flash Drive

Use the steps below to restore a test record from a USB Flash drive to the ATRT-03 S2's working memory:

- a. Make sure the USB Flash drive containing the test record(s) is inserted in the ATRT-03 S2's USB Flash drive port ("USB MEM" port). Then start from the "START-UP" menu:

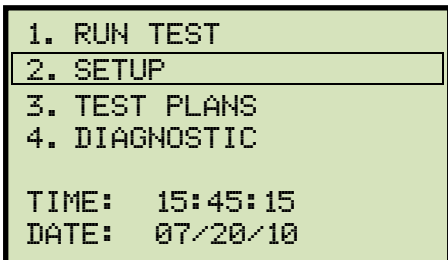

Press the **[2]** key (*SETUP*).

- b. The following screen will be displayed:

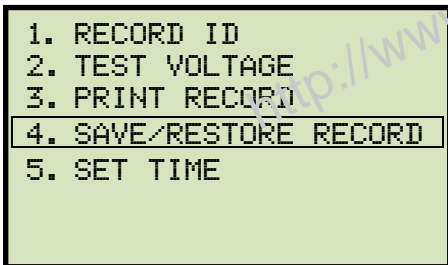

ATRT-03 S2 and ATRT-03A S2

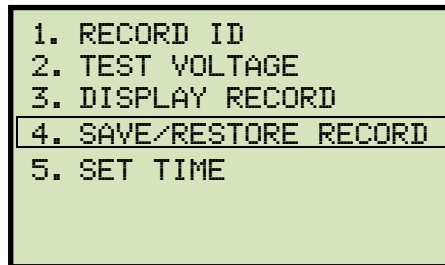

ATRT-03B S2

Press the **[4]** key (*SAVE/RESTORE RECORD*).

- c. The following screen will be displayed:

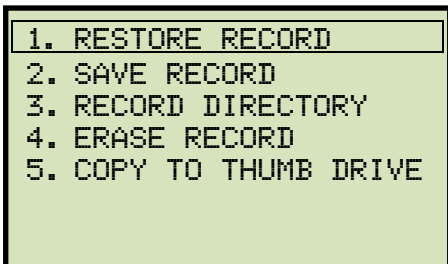

Press the **[1]** key (*RESTORE RECORD*).

- d. The following screen will be displayed:

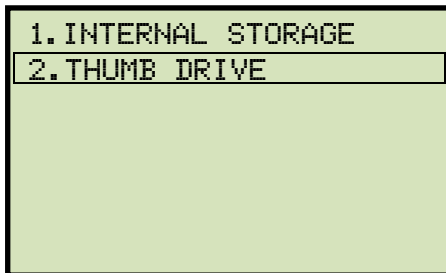

Press the **[2]** key (*THUMB DRIVE*).

- e. The following screen will be displayed:



Type the record number that you would like to restore using the alpha-numeric keypad. If you do not know the record number, you can first print (ATR-03 S2 and ATR-03A S2) or display (ATR-03B S2) a test record directory using the instructions in section 3.5.6 and 3.5.7.

Press the **[ENTER]** key.

- f. The test record will be restored to the unit's working memory and the following screen will be displayed:

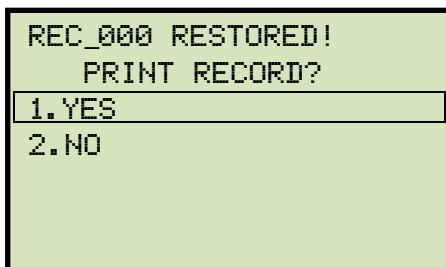

Press the **[1]** key (*YES*) to print or display the restored test record.

If using an ATRT-03 S2 or ATRT-03A S2, continue to step g.

If using an ATRT-03B S2, continue to step h.

- g. The following screen will be displayed:

```

PRINT RECORD
1.PRINT TO LCD
2.PRINT TO PRINTER
    
```

Press the **[1]** key (*PRINT TO LCD*) to display the test record date on the unit's LCD screen. **Continue to step h.**

Press the **[2]** key (*PRINT TO PRINTER*) to print the restored test record on the unit's built-in thermal printer. The following screen will be displayed:

```

PRINT FORMAT?
1.COLUMN
2.DETAILED
    
```

Press the **[1]** key (*COLUMN*) to print the test record in columnar format, or press the **[2]** key (*DETAILED*) to print the test record in detailed format. The test record will be printed, and you will be returned to the "START-UP" menu. The restored test record will remain loaded in the unit's working memory.

- h. The basic information about the restored test record will be displayed as shown below:

```

Ynd1
NUM TESTS: 1
07/22/10 07:52:50
    
```

Press the **[PAPER v Contrast]** key. The test record details will be displayed as shown below:

1	YND1		
	8 VOLTS		
	RATIO	mA	%DIFF
A	+10.057	0.8	0.46
B	+10.046	0.7	0.34
C	+10.057	0.8	0.46

Press the **[STOP]** key to return to the "START-UP" menu. The restored test record will remain loaded in the working memory.

<http://www.51082245.com>

3.5.4. Copying Test Records to a USB Flash Drive

Use the steps below to copy one or all test records from the unit's Flash EEPROM to a connected USB Flash drive:

- a. Make sure a USB Flash drive is connected to the unit's "USB MEM" port, and then start from the "START-UP" menu:

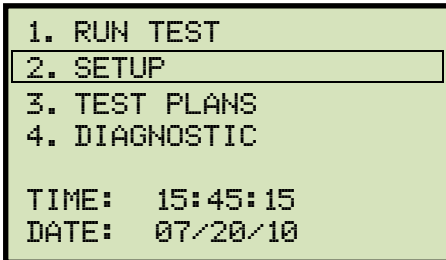

Press the **[2]** key (*SETUP*).

- b. The following screen will be displayed:

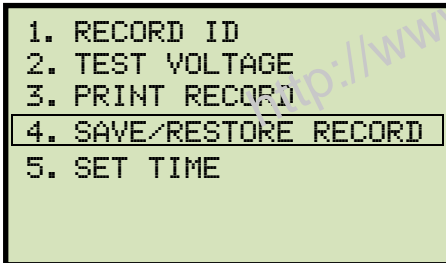

ATRT-03 S2 and ATRT-03A S2

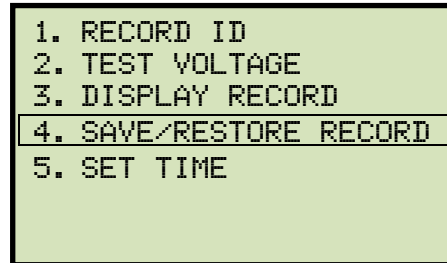

ATRT-03B S2

Press the **[4]** key (*SAVE/RESTORE RECORD*).

- c. The following screen will be displayed:

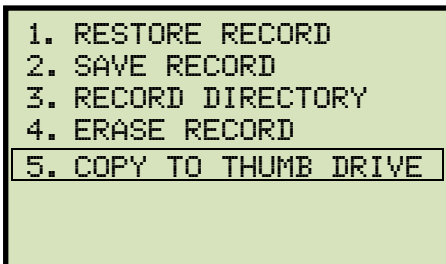

Press the **[5]** key (*COPY TO THUMB DRIVE*).

- d. The following screen will be displayed:

```
COPY REC TO THUMB DRV
1.COPY SINGLE RECORD
2.COPY ALL RECORDS
```

1. *COPY SINGLE RECORD*

Press the **[1]** key (*COPY SINGLE RECORD*) to copy a single test record from the ATRT-03 S2's Flash EEPROM to the connected USB Flash drive. The following screen will be displayed:

```
ENTER RECORD NUMBER
TO COPY TO FLASH DRV
NUMBER:
```

Type the record number using the alpha-numeric keypad and then press the **[ENTER]** key (If you don't know the record number, you can first print or display a test record directory using the instructions in section 3.5.6 and 3.5.7, respectively). The test record will be copied to the USB Flash drive and the following screen will be displayed:

```
REC_000 SAVED TO
THUMB DRIVE
```

Press any key to return to the "START-UP" menu.

2. *COPY ALL RECORDS*

Press the **[2]** key (*COPY ALL RECORDS*) to copy all test records from the ATRT-03 S2's Flash EEPROM to the connected USB Flash drive. All test records will be copied from the unit to the connected USB Flash drive. The following screen will be displayed when the process is finished:

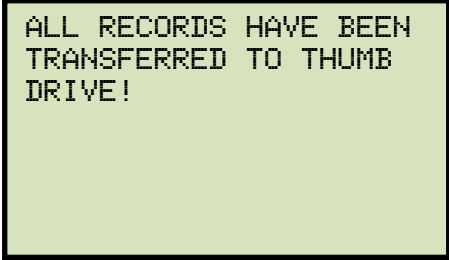

ALL RECORDS HAVE BEEN
TRANSFERRED TO THUMB
DRIVE!

Press any key to return to the "START-UP" menu.

<http://www.51082245.com>

3.5.5. Printing or Displaying a Test Record

You can print (ATRT-03 S2 and ATRT-03A S2 only) or display (all models) a test record at the time that it is restored (see section 3.5.1 and 3.5.3), or you can restore it to the working memory and print or display it later. To print or display the current test record in the working memory:

- Perform a test or restore a test record to the working memory (see section 3.5.1 and 3.5.3) and then start from the "START-UP" menu:

```

1. RUN TEST
2. SETUP
3. TEST PLANS
4. DIAGNOSTIC

TIME: 15:45:15
DATE: 07/20/10
  
```

Press the **[2]** key (*SETUP*).

- The following screen will be displayed:

```

1. RECORD ID
2. TEST VOLTAGE
3. PRINT RECORD
4. SAVE/RESTORE RECORD
5. SET TIME
  
```

ATRT-03 S2 and ATRT-03A S2

```

1. RECORD ID
2. TEST VOLTAGE
3. DISPLAY RECORD
4. SAVE/RESTORE RECORD
5. SET TIME
  
```

ATRT-03B S2

Press the **[3]** key.

If using an ATRT-03 S2 or ATRT-03A S2, continue to step c.

If using an ATRT-03B S2, continue to step d.

- c. The following screen will be displayed:

```

PRINT RECORD
1.PRINT TO LCD
2.PRINT TO PRINTER
    
```

Press the **[1]** key (*PRINT TO LCD*) to display the test record date on the unit's LCD screen. **Continue to step d.**

Press the **[2]** key (*PRINT TO PRINTER*) to print the restored test record on the unit's built-in thermal printer. The following screen will be displayed:

```

PRINT FORMAT?
1.COLUMN
2.DETAILED
    
```

Press the **[1]** key (*COLUMN*) to print the test record in columnar format, or press the **[2]** key (*DETAILED*) to print the test record in detailed format. The test record will be printed, and you will be returned to the "START-UP" menu.

- d. The basic information about the restored test record will be displayed as shown below:

```

YNd1
NUM TESTS: 1
07/22/10 07:52:50
    
```

Press the **[PAPER v Contrast]** key. The test record details will be displayed as shown below:

1	YND1		
	8 VOLTS		
	RATIO	mA	%DIFF
A	+10.057	0.8	0.46
B	+10.046	0.7	0.34
C	+10.057	0.8	0.46

Press the **[STOP]** key to return to the "START-UP" menu. The restored test record will remain loaded in the working memory.

<http://www.51082245.com>

3.5.6. Printing a Test Record Directory (ATRT-03 S2 and ATRT-03A S2 Only)

Follow the steps below to print a directory of the test records stored in the unit's Flash EEPROM or on a connected USB Flash drive (ATRT-03 S2 and ATRT-03A S2 only):

- a. Start from the "START-UP" menu:

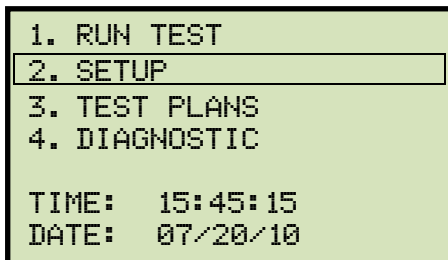

Press the **[2]** key (*SETUP*)

- b. The following screen will be displayed:

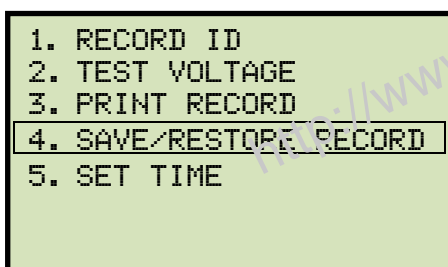

Press the **[4]** key (*SAVE/RESTORE RECORD*).

- c. The following screen will be displayed:

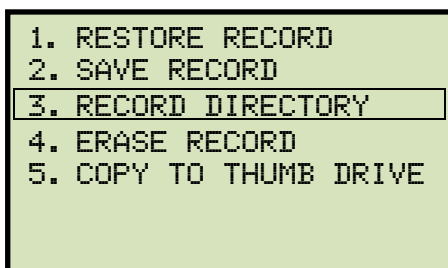

Option 5 (*COPY TO THUMB DRIVE*) is listed only if a USB Flash drive is connected to the unit.

NOTE

Press the **[3]** key (*RECORD DIRECTORY*)

If a USB Flash drive is connected to the unit, continue to step d.

If a USB Flash drive is NOT connected to the unit, continue to step e.

d. The following screen will be displayed:

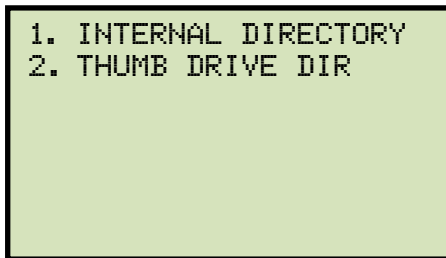

```
1. INTERNAL DIRECTORY
2. THUMB DRIVE DIR
```

1. *INTERNAL DIRECTORY*

Press the **[1]** key (*INTERNAL DIRECTORY*) to print a directory of the test records stored in the unit's Flash EEPROM. **Continue to step e.**

2. THUMB DRIVE DIR

Press the **[2]** key (*THUMB DRIVE DIR*) to print a directory of the test records stored on the connected USB Flash drive. A full directory of the test records stored on the USB Flash drive will be printed and you will be returned to the "START-UP" menu. Please see Figure 20 for a sample thumb drive directory printout.

e. The following screen will be displayed:

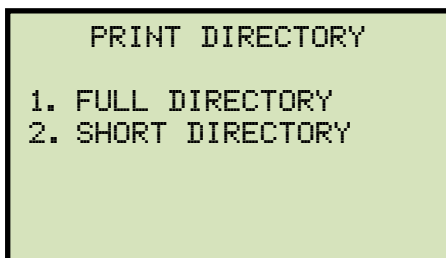

```
PRINT DIRECTORY
1. FULL DIRECTORY
2. SHORT DIRECTORY
```

Press the **[1]** key (*FULL DIRECTORY*) to print a full directory listing. This option will print all test record headers. The full record directory will be printed and you will be returned to the "START-UP" menu.

Press the **[2]** key (*SHORT DIRECTORY*) to print a short directory consisting of the last twelve record headers. The short record directory will be printed and you will be returned to the "START-UP" menu.

Please see Figure 21 for a sample internal Flash EEPROM test record directory printout.

THUMB DRV DIR	
THUMB DRV FILENAME: REC_000	
DATE/TIME: 07/22/10	14:55:03
TYPE: YNd1	
NUMBER OF TESTS: 1	
STATION:	
CIRCUIT:	
MFR:	
MODEL:	
S/N:	
KVA RTG: 3	
THUMB DRV FILENAME: REC_001	
DATE/TIME: 07/22/10	07:52:50
TYPE: YNd1	
NUMBER OF TESTS: 1	
STATION:	
CIRCUIT:	
MFR:	
MODEL:	
S/N:	
KVA RTG: 3	

Figure 20. Typical USB Flash Drive (Thumb Drive) Test Record Directory Printout

TEST DIRECTORY	
RECORD NUMBER: 4	
DATE/TIME: 07/22/10	07:52:50
TYPE: YNd1	
NUMBER OF TESTS: 1	
STATION:	
CIRCUIT:	
MFR:	
MODEL:	
S/N:	
KVA RTG: 3	
RECORD NUMBER: 3	
DATE/TIME: 07/22/10	07:44:36
TYPE: YNd1	
NUMBER OF TESTS: 1	
STATION:	
CIRCUIT:	
MFR:	
MODEL:	
S/N:	
KVA RTG: 3	
RECORD NUMBER: 2	
DATE/TIME: 07/21/10	14:59:35
TYPE: Dyn1	
NUMBER OF TESTS: 1	
STATION:	
CIRCUIT:	
MFR:	
MODEL:	
S/N:	
KVA RTG: 3	
RECORD NUMBER: 1	
DATE/TIME: 07/21/10	09:05:37
TYPE: SINGLE PHASE XFORMER	
NUMBER OF TESTS: 1	
STATION:	
CIRCUIT:	
MFR:	
MODEL:	
S/N:	
KVA RTG: 3	

Figure 21. Typical Internal Flash EEPROM Test Record Directory Printout

3.5.7. Viewing a Test Record Directory on the LCD Screen (ATRT-03B S2 Only)

Follow the steps below to view a directory of all the test records stored in the ATRT-03B S2's internal Flash EEPROM:

- a. Start from the "START-UP" menu:

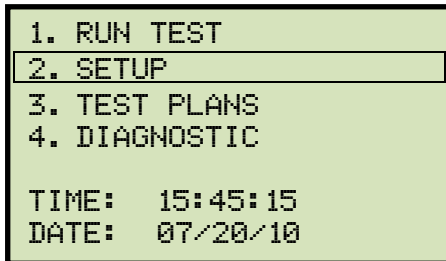

Press the **[2]** key (*SETUP*)

- b. The following screen will be displayed:

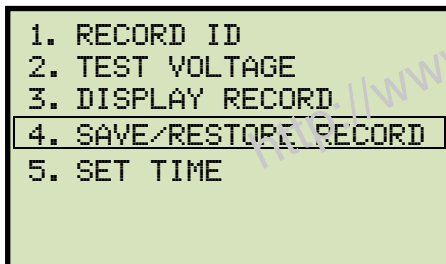

Press the **[4]** key (*SAVE/RESTORE RECORD*).

- c. The following screen will be displayed:

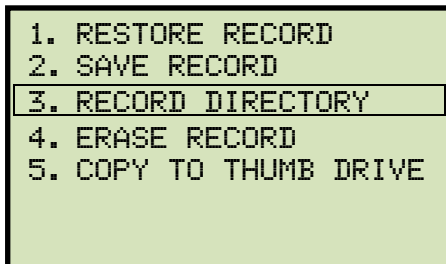

Press the **[3]** key (*RECORD DIRECTORY*).

- d. The following screen will be displayed:

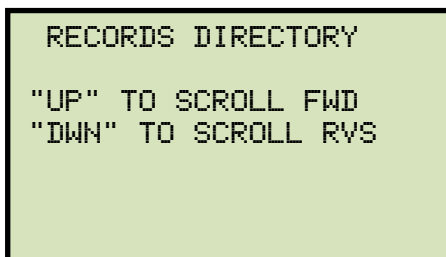

Press the **[PAPER ^ Contrast]** or **[PAPER v Contrast]** key to scroll through the test record directory. The test record header will be displayed as shown:

```
#1 07/22/10 09:07
YND1
1 TESTS
```

You can continue to scroll through the record directory by pressing the **[PAPER ^ Contrast]** and **[PAPER ∨ Contrast]** keys. Press the **[STOP]** key to return to the "START-UP" menu.

<http://www.51082245.com>

3.5.8. Erasing Test Records from the Flash EEPROM

Follow the steps below to erase test records from the Flash EEPROM:

- a. Start from the "START-UP" menu:

```

1. RUN TEST
2. SETUP
3. TEST PLANS
4. DIAGNOSTIC

TIME: 15:45:15
DATE: 07/20/10

```

Press the **[2]** key (*SETUP*).

- b. The following screen will be displayed:

```

1. RECORD ID
2. TEST VOLTAGE
3. PRINT RECORD
4. SAVE/RESTORE RECORD
5. SET TIME

```

ATRT-03 S2 and ATRT-03A S2

```

1. RECORD ID
2. TEST VOLTAGE
3. DISPLAY RECORD
4. SAVE/RESTORE RECORD
5. SET TIME

```

ATRT-03B S2

Press the **[4]** key (*SAVE/RESTORE RECORD*).

- c. The following screen will be displayed:

```

1. RESTORE RECORD
2. SAVE RECORD
3. RECORD DIRECTORY
4. ERASE RECORD

```

Press the **[4]** key (*ERASE RECORD*).

- d. The following screen will be displayed:

```

ERASE RECORD

1.ERASE SINGLE REC.
2.ERASE ALL RECORDS

"STOP" TO EXIT

```



If you have a USB Flash drive inserted in the ATRT-03 S2's "USB MEM" port, the following screen will be displayed instead of the above screen:

NOTE

```
1.ERASE INTERNAL REC
2.ERASE THUMB DRV REC
```

Press the **[1]** key (*ERASE INTERNAL REC*).

The following screen will be displayed:

```
ERASE RECORD
1.ERASE SINGLE REC.
2.ERASE ALL RECORDS
"STOP" TO EXIT
```

Continue with the steps below.

1. *ERASE SINGLE REC.*

Press the **[1]** key (*ERASE SINGLE REC.*) to erase a single test record from the unit's internal Flash EEPROM. The following screen will be displayed:

```
ERASE RECORD
NUMBER:
```



NOTE

You can cancel the process and return to the "START-UP" menu by pressing the **[STOP]** key.

Type the record number that you would like to erase using the alpha-numeric keypad and then press the **[ENTER]** key. If you do not know the test record number, you can first print or view a test record directory using the instructions in section 3.5.6 and 3.5.7, respectively.

The following screen will be displayed while the record is being erased:

```
ERASING RECORD  
PLEASE WAIT...
```

The following screen will be displayed when the test record has been completely erased:

```
RECORD NUMBER 8  
ERASED!
```

Press any key to continue. You will be returned to the beginning of step d.

2. ERASE ALL RECORDS

Press the **[2]** key (*ERASE ALL RECORDS*) to erase all the test records from the unit's internal Flash EEPROM. The following warning screen will be displayed:

```
ERASE ALL RECORDS!  
ARE YOU SURE?  
  
"ENTER" TO CONTINUE.
```

You can press the **[STOP]** key to cancel the process and return to the "START-UP" menu.

Press the **[ENTER]** key to proceed with deleting all the test records from the unit's Flash EEPROM. The following screen will be displayed during the erasure process:

```
ERASING RECORDS  
PLEASE WAIT...
```

The following screen will be displayed when all test records have been completely erased:



Press any key to return to the "START-UP" menu.

<http://www.51082245.com>

3.5.9. Erasing Test Records from a USB Flash Drive

Follow the steps below to erase test records from a USB Flash drive:

- a. Make sure a USB Flash drive is connected to the unit's "USB MEM" port, and then start from the "START-UP" menu:

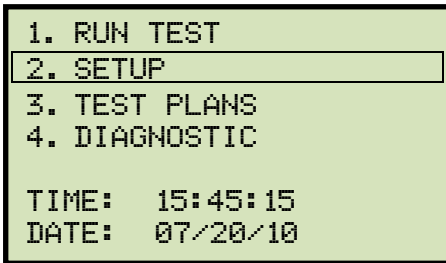

Press the **[2]** key (*SETUP*).

- b. The following screen will be displayed:

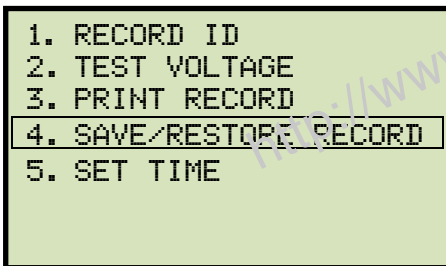

ATRT-03 S2 and ATRT-03A S2

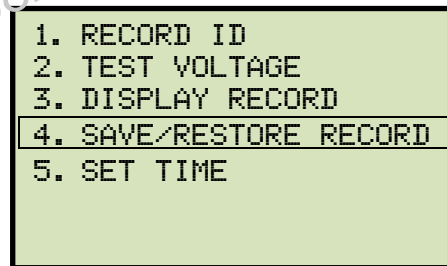

ATRT-03B S2

Press the **[4]** key (*SAVE/RESTORE RECORD*).

- c. The following screen will be displayed:

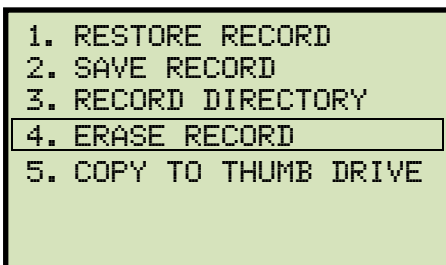

Press the **[4]** key (*ERASE RECORD*).

d. The following screen will be displayed:

```

1.ERASE INTERNAL REC
2.ERASE THUMB DRV REC
    
```

Press the **[2]** key (*ERASE THUMB DRV REC*).

e. The following screen will be displayed:

```

          ERASE RECORD
1.ERASE SINGLE REC.
2.ERASE ALL RECORDS
          "STOP" TO EXIT
    
```

1. *ERASE SINGLE REC.*

Press the **[1]** key (*ERASE SINGLE REC.*) to erase a single test record from the connected USB Flash drive. The following screen will be displayed:

```

          ERASE THUMB DRIVE
          REC_
    
```

Type the record number that you would like to erase using the alpha-numeric keypad and then press the **[ENTER]** key. If you do not know the test record number, you can first print a test record directory using the instructions in section 3.5.6 (ATRT-03 S2 and ATRT-03A S2 only).

The test record will be erased from the USB Flash drive and the following screen will be displayed:

```

          THUMB DRIVE REC0000
          ERASED!
    
```

Press any key to continue. You will be returned to the beginning of step e. Press the **[STOP]** key to return to the "START-UP" menu.

2. ERASE ALL RECORDS

Press the **[2]** key (*ERASE ALL RECORDS*) to delete all test records from the connected USB Flash drive. The following warning screen will be displayed:

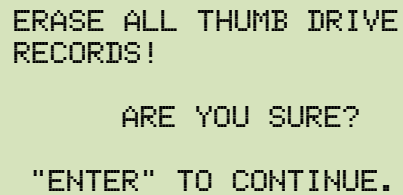

```
ERASE ALL THUMB DRIVE
RECORDS!

      ARE YOU SURE?

"ENTER" TO CONTINUE.
```

Press the **[STOP]** key if you do not want to erase all the test records. You will be returned to the "START-UP" menu.

Press the **[ENTER]** key to proceed with deleting all the test records from the connected USB Flash drive. The following screen will be displayed when all the records have been erased:

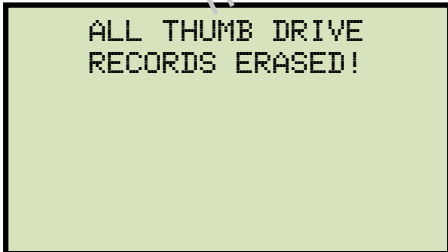

```
ALL THUMB DRIVE
RECORDS ERASED!
```

Press any key to return to the "START-UP" menu.

3.6 Working With Test Plans

The ATRT-03 S2 comes with the Vanguard Transformer Turns Ratio Analyzer Series 2 software (TTRA S2) that can be used to create transformer test plans on a PC (see the TTRA S2 software manual for details). Test plans can then be transferred to the ATRT-03 S2 and used to quickly perform tests.

3.6.1. Performing a Test Using a Transformer Test Plan

Follow the steps below to perform a test using a test plan:

- a. Start from the "START-UP" menu:

```

1. RUN TEST
2. SETUP
3. TEST PLANS
4. DIAGNOSTIC

TIME: 15:45:15
DATE: 07/20/10
    
```

Press the **[3]** key (*TEST PLANS*).

- b. The following screen will be displayed:

```

1. LOAD TEST PLAN
2. UNLOAD TEST PLAN
3. PLAN DIRECTORY
4. PRINT TEST PLAN
5. ERASE TEST PLAN
6. SAVE TEST PLAN
7. COPY TO THUMB DRIVE
    
```



Option 7 (*COPY TO THUMB DRIVE*) will be available only if a USB Flash drive is connected to the "USB MEM" port.

NOTE

Press the **[1]** key (*LOAD TEST PLAN*).

If you have a USB Flash drive connected to the unit, **continue to step c.**

If you do NOT have a USB Flash drive connected to the unit, **continue to step d.**

- c. The following screen will be displayed:

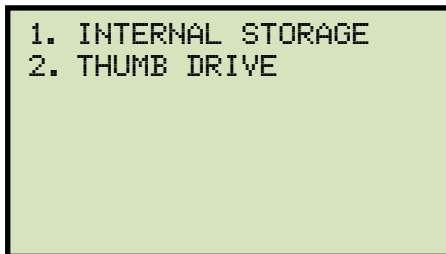

1. *INTERNAL STORAGE*

Press the **[1]** key (*INTERNAL STORAGE*) to load a test plan from the unit's Flash EEPROM. **Continue to step d.**

2. *THUMB DRIVE*

Press the **[2]** key (*THUMB DRIVE*) to load a test plan from the connected USB Flash drive. The following screen will be displayed:

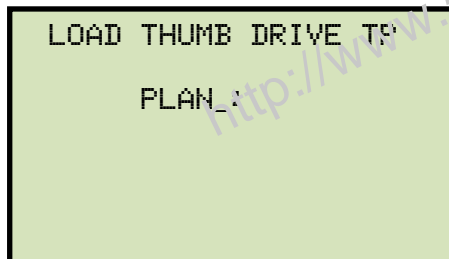

Type the test plan number to load from the USB Flash drive and then press the **[ENTER]** key.

The following screen will be displayed:

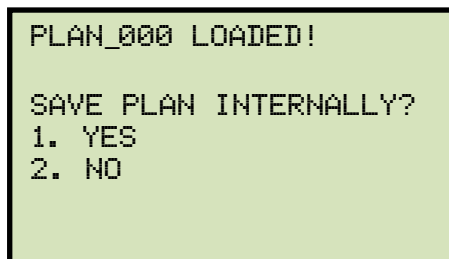

Press the **[2]** key (*NO*) to not save the test plan in the unit's Flash EEPROM and to just load it in the working memory. The test plan will be loaded in the working memory and you will be returned to the "START-UP" menu. **Continue to step e to perform a test using the loaded test plan.**

Press the **[1]** key (*YES*) to load the test plan to the working memory and also save it in the unit's Flash EEPROM. The following screen will be displayed:

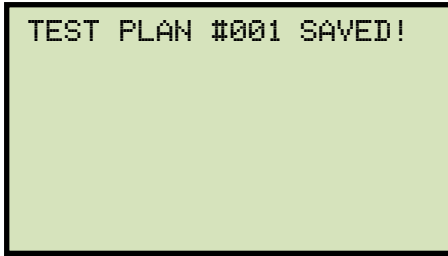

Press any key to continue. The test plan will be loaded in the working memory and also saved to the unit's Flash EEPROM. You will be returned to the "START-UP" menu. **Continue to step e to perform a test using the loaded test plan.**

- d. The following screen will be displayed:

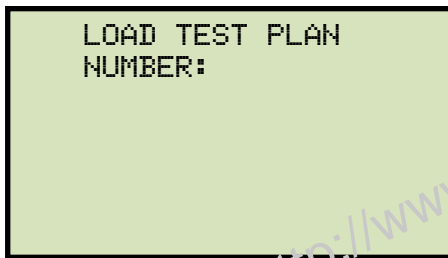

Type the test plan number to load from the unit's Flash EEPROM and then press the **[ENTER]** key. The test plan will be loaded from the Flash EEPROM and you will be returned to the "START-UP" menu. **Continue to step e to perform a test using the loaded test plan.**

- e. Start from the "START-UP" menu again to run a test using the loaded test plan from the steps above:

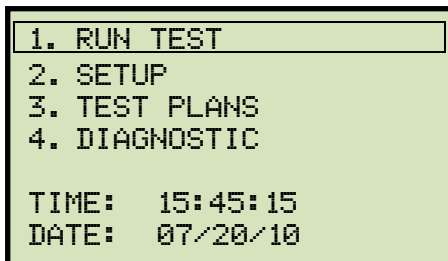

Press the **[1]** key (*RUN TEST*).

- f. The following screen will be displayed (test details will differ depending on the test type defined in the test plan):

```

TP #1      YND1
TAPS:    2

TEST PLAN LOADED
1. CONTINUE
2. UNLOAD TEST PLAN
    
```



The above screen will be displayed only if a test plan is loaded first.

NOTE

Press the **[1]** key (*CONTINUE*).

- g. The following screen will be displayed:

```

TAP NUMBER 1

H VTG:    1734
X VTG:    100

"START" TO RUN TEST
    
```

Set the transformer to the tap position indicated on the LCD screen. Press the **[START]** key to run the test using the test plan.

- h. The unit will start performing the test and the screen will be updated with the test results as shown:

```

TEST RESULTS
RATIO  MA  %DIFF
A +10.057 0.8 0.46 P
B +10.046 0.7 0.34 P
C +10.057 0.8 0.46 P

XFMR TYPE: YND1
    
```



For each phase (A, B, and C) a "P" or "F" will be displayed to indicate Pass or Fail, respectively.

NOTE

Press any key to continue.

If using an ATRT-03 S2 or ATRT-03A S2, continue to step i.

If using an ATRT-03B S2, continue to step k.

- i. The following screen will be displayed:

```

PRINT TEST RESULTS?
1. YES
2. NO
    
```

Press the **[1]** key (*YES*) to print the test results.

- j. The following screen will be displayed:

```

PRINT FORMAT?
1. COLUMN
2. DETAILED
    
```

Press the **[1]** key (*COLUMN*) to print a columnar report or press the **[2]** key (*DETAILED*) to print a detailed report. Please see Figure 22 for a sample test results printout.

- k. The following screen will be displayed:

```

KEEP THIS READING?
1. YES
2. NO
    
```

Press the **[1]** key (*YES*) to save the reading.

- l. The following screen will be displayed:

```

TEST SAVED
    
```

Press any key to continue.

- m. If the test plan included multiple tests, the start-up screen for the next test will be displayed as shown:

```
TAP NUMBER 2  
H VTG: 4160  
X VTG: 240  
"START" TO RUN TEST
```

Repeat steps h through l for this test.

- n. The following screen will be displayed after the last defined test in the test plan has been performed:

```
END OF TEST PLAN
```

Press any key to continue.

- o. The following screen will be displayed:

```
SAVE THIS RECORD?  
1. YES  
2. NO
```

Press the **[1]** key (YES) to save the test record to the unit's Flash EEPROM.

- p. The following screen will be displayed momentarily:

```
SAVING RECORD...  
  
PLEASE WAIT...
```

The following confirmation screen will then be displayed:

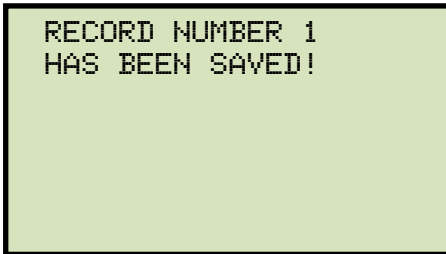

Press any key to return to the "START-UP" menu.

TRANSFORMER TEST RESULTS				
DATE: 08/03/10		TIME: 07:15:55		
COMPANY: VANGUARD INSTRUMENTS				
STATION: FACTORY				
CIRCUIT: 120V				
MFR:				
MODEL:				
S/N:				
KVA RTG: 500				
OPERATOR: HAI				
TEST VOLTAGE = 8 V				
TYPE: YNd1				
H TAP: _____		H VOLTAGE: 1,734		
X TAP: _____		X VOLTAGE: 100		
CALCULATED RATIO: 10.000				
PHS	M-RATIO	mA	PHASE	%DIFF
A	+10.057	0.8	0.09	0.46 P
B	+10.046	0.7	0.03	0.43 P
C	+10.057	0.8	0.04	0.46 P
DATE: 08/03/10		TIME: 07:15:55		

Figure 22. Test Plan Test Results Printout

3.6.2. Unloading a Test Plan From the Working Memory

Follow the steps below to unload a test plan from the working memory:

- a. Start from the "START-UP" menu:

```
1. RUN TEST
2. SETUP
3. TEST PLANS
4. DIAGNOSTIC

TIME: 15:45:15
DATE: 07/20/10
```

Press the **[3]** key (*TEST PLANS*).

- b. The following screen will be displayed:

```
1. LOAD TEST PLAN
2. UNLOAD TEST PLAN
3. PLAN DIRECTORY
4. PRINT TEST PLAN
5. ERASE TEST PLAN
6. SAVE TEST PLAN
7. COPY TO THUMB DRIVE
```

Press the **[2]** key (*UNLOAD TEST PLAN*).

- c. The test plan will be unloaded from the working memory, and the following screen will be displayed:

```
TEST PLAN UNLOADED!
```

Press any key to return to the "START-UP" menu.

3.6.3. Printing a Test Plan Directory (ATRT-03 S2 and ATRT-03A S2 Only)

Follow the steps below to print a directory of the test plans stored in the unit's Flash EEPROM or on a connected USB Flash drive (ATRT-03 S2 and ATRT-03A S2 only):

- a. Start from the "START-UP" menu:

```

1. RUN TEST
2. SETUP
3. TEST PLANS
4. DIAGNOSTIC

TIME: 15:45:15
DATE: 07/20/10
    
```

Press the **[3]** key (*TEST PLANS*).

- b. The following screen will be displayed:

```

1. LOAD TEST PLAN
2. UNLOAD TEST PLAN
3. PLAN DIRECTORY
4. PRINT TEST PLAN
5. ERASE TEST PLAN
6. SAVE TEST PLAN
7. COPY TO THUMB DRIVE
    
```

Press the **[3]** key (*PLAN DIRECTORY*).

If a USB Flash drive is NOT connected to the unit, a directory of the test plans stored in the unit's Flash EEPROM will be printed, and then you will be returned to the "START-UP" menu.

If a USB Flash drive is connected to the unit, continue to step c.

- c. The following screen will be displayed:

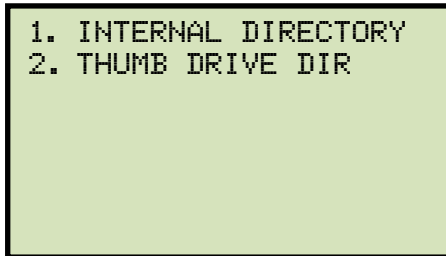

1. *INTERNAL DIRECTORY*

Press the **[1]** key (*INTERNAL DIRECTORY*) to print a directory of the test plans stored in the unit's Flash EEPROM. The directory will be printed and you will be returned to the "START-UP" menu.

2. *THUMB DRIVE DIR*

Press the **[2]** key (*THUMB DRIVE DIR*) to print a directory of the test plans stored on the connected USB Flash drive. A full directory of the test plans stored on the USB Flash drive will be printed and you will be returned to the "START-UP" menu.

3.6.4. Viewing a Test Plan Directory on the LCD Screen (ATRT-03B S2 Only)

Follow the steps below to view a directory of all the test plans stored in the ATRT-03B S2's internal Flash EEPROM:

- a. Start from the "START-UP" menu:

```

1. RUN TEST
2. SETUP
3. TEST PLANS
4. DIAGNOSTIC

TIME: 15:45:15
DATE: 07/20/10
    
```

Press the **[3]** key (*TEST PLANS*).

- b. The following screen will be displayed:

```

1. LOAD TEST PLAN
2. UNLOAD TEST PLAN
3. PLAN DIRECTORY
4. ERASE TEST PLAN
5. SAVE TEST PLAN
    
```

Press the **[3]** key (*PLAN DIRECTORY*).

- c. The following screen will be displayed:

```

TEST PLAN DIRECTORY

"UP" TO SCROLL FWD
"DWN" TO SCROLL RVS
    
```

Press the **[PAPER ^ Contrast]** or **[PAPER v Contrast]** key to scroll through the test plan directory. The test plan header will be displayed as shown:

```

#1  YND1
NUM TESTS: 2

GE
EXAMPLE #3
5KVA
    
```

You can continue to scroll through the test plan directory by pressing the **[PAPER ^ Contrast]** and **[PAPER v Contrast]** keys. Press the **[STOP]** key to return to the "START-UP" menu.

<http://www.51082245.com>

3.6.5. Printing a Test Plan (ATRT-03 S2 and ATRT-03A S2 Only)

Follow the steps below to print a test plan from the internal Flash EEPROM or from a connected USB Flash drive:

- a. Start from the "START-UP" menu:

```

1. RUN TEST
2. SETUP
3. TEST PLANS
4. DIAGNOSTIC

TIME: 15:45:15
DATE: 07/20/10
    
```

Press the **[3]** key (*TEST PLANS*).

- b. The following screen will be displayed:

```

1. LOAD TEST PLAN
2. UNLOAD TEST PLAN
3. PLAN DIRECTORY
4. PRINT TEST PLAN
5. ERASE TEST PLAN
6. SAVE TEST PLAN
7. COPY TO THUMB DRIVE
    
```

Press the **[4]** key (*PRINT TEST PLAN*).

If a USB Flash drive is connected to the unit, continue to step c.

If a USB Flash drive is NOT connected to the unit, continue to step d.

- c. The following screen will be displayed:

```

1. PRINT INTERNAL TP
2. PRINT FLASH DRV TP
    
```

1. *PRINT INTERNAL TP*

Press the **[1]** key (*PRINT INTERNAL TP*) to print a test plan from the unit's internal Flash EEPROM. **Continue to step d.**

2. *PRINT FLASH DRV TP*

Press the **[2]** key (*PRINT FLASH DRV TP*) to print a test plan from a connected USB Flash drive. The following screen will be displayed:

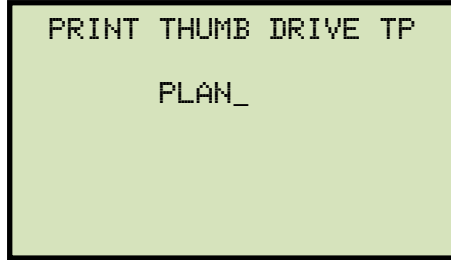

Type the test plan number using the alpha-numeric keypad and then press the **[ENTER]** key. The test plan details will be printed on the unit's printer and you will be returned to the "START-UP" menu. A sample test plan printout is shown in Figure 23.

- d. The following screen will be displayed:

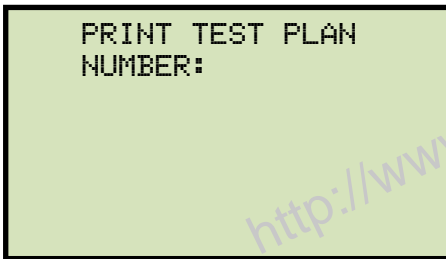

Type the test plan number using the alpha-numeric keypad and then press the **[ENTER]** key. The test plan will be printed on the unit's printer and you will be returned to the "START-UP" menu. A sample test plan printout is shown in Figure 24.

THUMB DRIVE PLAN_000	
TYPE: YNd1	
TEST VOLTAGE = 40 U	
COMPANY:	
MFR:	GE
MODEL:	Example #3
KVA RTG:	5KVA
COMMENTS:	
MAX DEVIATION: 0.50%	
NUMBER OF TAPS: 2	
TAP #1	
H VOLTAGE:	002,400 U
X VOLTAGE:	000,120 U
TAP #2	
H VOLTAGE:	004,160 U
X VOLTAGE:	000,240 U

Figure 23. Sample Printout of a Test Plan from a USB Flash Drive

TEST PLAN 1	
TYPE: YNd1	
TEST VOLTAGE = 40 U	
COMPANY:	
MFR:	GE
MODEL:	Example #3
KVA RTG:	5KVA
COMMENTS:	
MAX DEVIATION: 0.50%	
NUMBER OF TAPS: 2	
TAP #1	
H VOLTAGE:	002,400 U
X VOLTAGE:	000,120 U
TAP #2	
H VOLTAGE:	004,160 U
X VOLTAGE:	000,240 U

Figure 24. Sample Printout of a Test Plan from Internal Memory

<http://www.51082245.com>

3.6.6. Saving a Test Plan

Use the steps below to save a test plan from the working memory to the unit's Flash EEPROM or to a connected USB Flash drive:

- a. Make sure a test plan is loaded in the working memory, and then start from the "START-UP" menu:

```

1. RUN TEST
2. SETUP
3. TEST PLANS
4. DIAGNOSTIC

TIME: 15:45:15
DATE: 07/20/10

```

Press the **[3]** key (*TEST PLANS*).

- b. The following screen will be displayed:

```

1. LOAD TEST PLAN
2. UNLOAD TEST PLAN
3. PLAN DIRECTORY
4. PRINT TEST PLAN
5. ERASE TEST PLAN
6. SAVE TEST PLAN
7. COPY TO THUMB DRIVE

```

Press the **[6]** key (*SAVE TEST PLAN*).

If a USB Flash drive is connected to the unit, continue to step c.

If a USB Flash drive is NOT connected to the unit, continue to step d.

- c. The following screen will be displayed:

```

1. SAVE INTERNALLY
2. SAVE TO THUMB DRIVE

```

1. *SAVE INTERNALLY*

Press the **[1]** key (*SAVE INTERNALLY*) to save the test plan to the unit's Flash EEPROM. **Continue to step d.**

2. *SAVE TO THUMB DRIVE*

Press the **[2]** key (*SAVE TO THUMB DRIVE*) to save the test plan to the connected USB Flash drive. The test plan will be saved to the USB Flash drive and the following screen will be displayed:



Press any key to return to the "START-UP" menu.

- d. The test plan will be saved to the unit's Flash EEPROM and the following screen will be displayed:

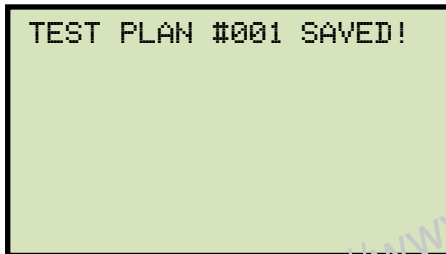

Press any key to return to the "START-UP" menu.

3.6.7. Copying a Test Plan to a USB Flash Drive

Use the steps below to copy a test plan from the unit's Flash EEPROM to a connected USB Flash drive:

- a. Make sure a USB Flash drive is connected to the unit's "USB MEM" port, and then start from the "START-UP" menu:

```

1. RUN TEST
2. SETUP
3. TEST PLANS
4. DIAGNOSTIC

TIME: 15:45:15
DATE: 07/20/10
    
```

Press the **[3]** key (*TEST PLANS*).

- b. The following screen will be displayed:

```

1. LOAD TEST PLAN
2. UNLOAD TEST PLAN
3. PLAN DIRECTORY
4. PRINT TEST PLAN
5. ERASE TEST PLAN
6. SAVE TEST PLAN
7. COPY TO THUMB DRIVE
    
```

ATRT-03 S2 and ATRT-03A S2

Press the **[7]** key.

```

1. LOAD TEST PLAN
2. UNLOAD TEST PLAN
3. PLAN DIRECTORY
4. ERASE TEST PLAN
5. SAVE TEST PLAN
6. COPY TO THUMB DRIVE
    
```

ATRT-03B S2

Press the **[6]** key.

- c. The following screen will be displayed:

```

ENTER TP NUMBER
TO COPY TO FLASH DRV

TP NUMBER:
    
```

Type the test plan number using the alpha-numeric keypad and then press the **[ENTER]** key.

- d. The selected test plan will be copied to the USB Flash drive and the following message will be displayed:

TP 1 SAVED TO THUMB
DRIVE AS PLAN_003



Any existing test plans in the Flash drive will NOT be over-written.

NOTE

Press any key to return to the "START-UP" menu.

<http://www.51082245.com>

3.6.8. Erasing Test Plans

Follow the steps below to erase a test plan from the unit's Flash EEPROM or from a connected USB Flash drive:

- a. Start from the "START-UP" menu:

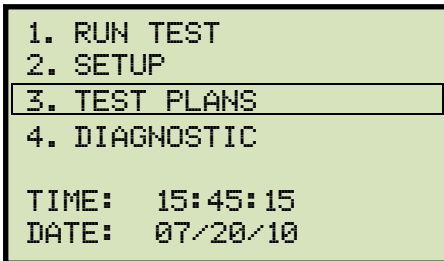

Press the **[3]** key (*TEST PLANS*).

- b. The following screen will be displayed:

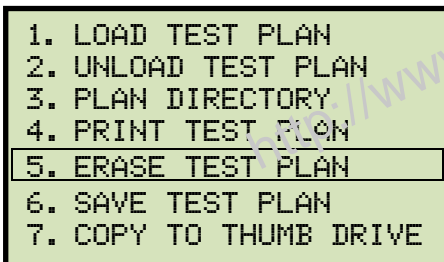

ATRT-03 S2 and ATRT-03A S2

Press the **[5]** key (*ERASE TEST PLAN*)

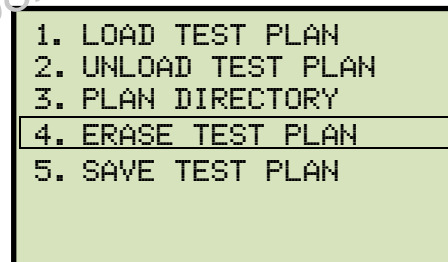

ATRT-03B S2

Press the **[4]** key (*ERASE TEST PLAN*)

If a USB Flash drive is connected to the unit, continue to step c.

If a USB Flash drive is NOT connected to the unit, continue to step d.

- c. The following screen will be displayed:

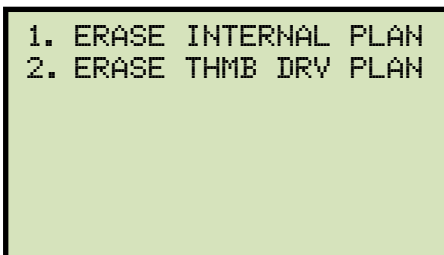

1. *ERASE INTERNAL PLAN*

Press the **[1]** key (*ERASE INTERNAL PLAN*) to erase test plans from the unit's Flash EEPROM. **Continue to step d.**

2. *ERASE THMB DRV PLAN*

Press the **[2]** key (*ERASE THMB DRV PLAN*) to erase test plans from a connected USB Flash drive. The following screen will be displayed:

```

ERASE TEST PLAN

1. ERASE SINGLE PLAN
2. ERASE ALL PLANS
    
```

1. ERASE SINGLE PLAN

Press the **[1]** key (*ERASE SINGLE PLAN*) to erase a single test plan from the connected USB Flash drive. The following screen will be displayed:

```

ERASE THUMB DRIVE

PLAN_
    
```

Type the test plan number using the alpha-numeric keypad and then press the **[ENTER]** key. The following screen will be displayed:

```

THUMB DRIVE PLAN_000
ERASED!
    
```

Press any key to return to the "START-UP" menu.

2. ERASE ALL PLANS

Press the **[2]** key (*ERASE ALL PLANS*) to erase all test plans from the connected USB Flash drive. The following warning screen will be displayed:

```

ERASE ALL THUMB DRIVE
TEST PLANS!

ARE YOU SURE?

"ENTER" TO CONTINUE
    
```

If you do NOT want to erase all the test plans from the connected USB Flash drive, press the **[STOP]** key. You will be returned to the "START-UP" menu.

To proceed with erasing all the test plans from the connected USB Flash drive, press the **[ENTER]** key. All test plans will be erased from the USB Flash drive and the following message will be displayed:

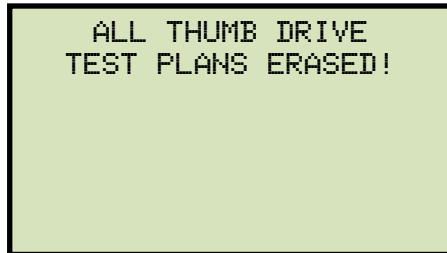

```
ALL THUMB DRIVE
TEST PLANS ERASED!
```

Press any key to return to the "START-UP" menu.

- d. The following screen will be displayed:

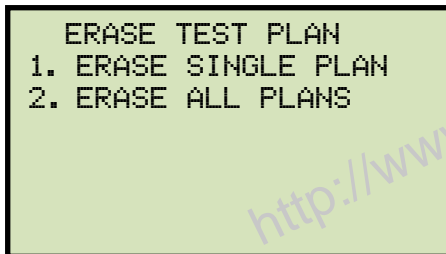

```
ERASE TEST PLAN
1. ERASE SINGLE PLAN
2. ERASE ALL PLANS
```

1. *ERASE SINGLE PLAN*

Press the **[1]** key (*ERASE SINGLE PLAN*) to erase a single test plan from the unit's internal Flash EEPROM. The following screen will be displayed:

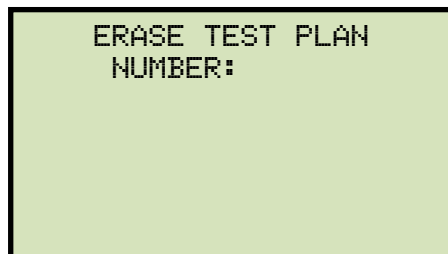

```
ERASE TEST PLAN
NUMBER:
```

Type the test plan number using the alpha-numeric keypad and then press the **[ENTER]** key. The test plan will be erased and the following message will be displayed:

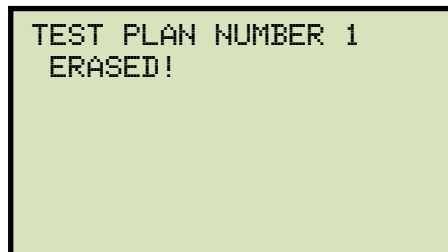

```
TEST PLAN NUMBER 1
ERASED!
```

Press any key to return to the "START-UP" menu.

2. ERASE ALL PLANS

Press the **[2]** key (*ERASE ALL PLANS*) to erase all test plans from the unit's internal Flash EEPROM. The following warning screen will be displayed:

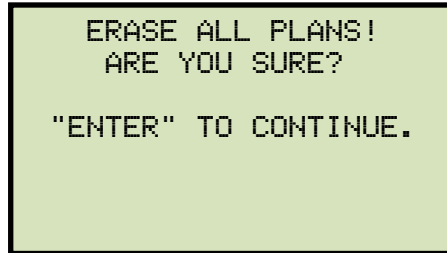

If you do NOT want to erase all the stored test plans from the unit's Flash EEPROM, press the **[STOP]** key. You will be returned to the "START-UP" menu.

To proceed with erasing all the test plans from the unit's Flash EEPROM, press the **[ENTER]** key. All test plans will be erased from the unit's Flash EEPROM and the following message will be displayed:



Press any key to return to the "START-UP" menu.

4.0 DIAGNOSTICS, VERIFICATION, AND TROUBLESHOOTING

4.1 Performing an H and X Cable Diagnostic Test

Use the steps below to perform a diagnostic test on the H and X cables:

- a. Start from the "START-UP" menu:

```
1. RUN TEST
2. SETUP
3. TEST PLANS
4. DIAGNOSTIC
-----
TIME: 15:45:15
DATE: 07/20/10
```

Press the **[4]** key (*DIAGNOSTIC*).

- b. The following screen will be displayed:

```
1. CABLE TEST
2. VERIFICATION TEST
```

Press the **[1]** key (*CABLE TEST*).

- c. The following screen will be displayed:

```
      CABLE TEST
CONNECT: H0-X0, H1-X1
         H2-X2, H3-X3

"ENTER" TO CONTINUE..
```

Connect the H and X cables per the on-screen instructions and then press the **[ENTER]** key.

- d. The following screen will be displayed while the cables are being tested:

```
      CABLE TEST
```

The screen will be updated with the status of each test as shown:

```

CABLE TEST
H0-X0, H1-X1: OK
H0-X0, H2-X2: OK
H0-X0, H3-X3: OK
    
```



“NOT OK” will be displayed for a failed diagnostic test.

NOTE

Press any key to return to the “START-UP” menu.

<http://www.51082245.com>

4.2 Performing a Verification Test

Use the steps below to perform a verification test on the ATRT-03 S2's electronics:

- a. Start from the "START-UP" menu:

```
1. RUN TEST
2. SETUP
3. TEST PLANS
4. DIAGNOSTIC

TIME: 15:45:15
DATE: 07/20/10
```

Press the **[4]** key (*DIAGNOSTIC*).

- b. The following screen will be displayed:

```
1. CABLE TEST
2. VERIFICATION TEST
```

Press the **[2]** key (*VERIFICATION TEST*).

- c. The following screen will be displayed:

```
VERIFICATION TEST
CONNECT: H0-X0, H1-X1
        H2-X2, H3-X3

"ENTER" TO CONTINUE..
```

Connect the H and X cables per the on-screen instructions and then press the **[ENTER]** key.

- d. The ATRT-03 S2 will start performing a DELTA-DELTA test. The following screen will be displayed momentarily:

```
DELTA-DELTA TEST
```

The screen will then be updated with the test results for each phase:

```

TEST RESULTS
RATIO    MA    %DIFF
A +1.0000 0001
B +1.0000 0001
C +1.0000 0001

XFMR TYPE: Dd0
    
```

The unit will then proceed to perform a Y to Y test. The following screen will be displayed momentarily:

```

Y TO Y TEST
    
```

The screen will then be updated with the test results for each phase:

```

TEST RESULTS
RATIO    MA    %DIFF
A +1.0000 0001
B +1.0000 0001
C +1.0000 0001

XFMR TYPE: YNy0
    
```

The following screen will be displayed when testing is finished:

```

TEST RESULTS
RATIO    MA    %DIFF
A +1.0000 0001
B +1.0000 0001
C +1.0000 0001

TEST COMPLETE
    
```



The ratio reading should be 1.0000 ±0.1% for all tests.

NOTE

Press any key to return to the "START-UP" menu.

5.0 UPGRADING FIRMWARE

The ATRT-03 S2's firmware is user-upgradeable. You can download the latest firmware from the Vanguard Instruments Company web site at <http://www.vanguard-instruments.com>. Use the steps below to download and install the latest ATRT-03 S2 firmware:

- a. Visit the Vanguard web site at <http://www.vanguard-instruments.com> and click on the "Downloads" button:



- b. You will be taken to the "Downloads" page and presented with a "Download Request Form":

REQUEST SOFTWARE/MANUAL DOWNLOADS

Please select the check boxes for the items you would like to download. For each selected item, please be sure to provide your product's serial number. Once we receive your download request, you will receive an email with links for the requested files. Fields in **RED** are required fields. Thank you.

Name: **E-Mail:**

Company: **Phone:**

Comments:

19140

Enter the security code shown above in the field below:

Circuit Breaker Timers							
Product	PC Software	Firmware	Software Manual	User's Manual	Spanish Manual	Product Demo	Serial Number
CBPS-300				<input type="checkbox"/>		<input type="checkbox"/>	<input style="width: 100%;" type="text"/>
CT-3500	<input type="checkbox"/>	<input type="checkbox"/>		<input type="checkbox"/>		<input type="checkbox"/>	<input style="width: 100%;" type="text"/>
CT-6500	<input type="checkbox"/>	<input type="checkbox"/>	<input type="checkbox"/>	<input type="checkbox"/>	<input type="checkbox"/>	<input type="checkbox"/>	<input style="width: 100%;" type="text"/>

Fill out all required fields (marked with red labels) and then click on the "Firmware" checkbox to the right of the "ATRT-03 S2" label. Then fill out the serial number field on the right. Click on the "Submit" button once all form fields have been filled out.

- c. The following confirmation page will be displayed:

REQUEST SOFTWARE/MANUAL DOWNLOADS

We have received your download request and an email will be sent to you with the download links within the next 24 hours. Thank you.

Copyright 2005, VIC

You will also receive an email confirming the receipt of your download request. Once your request has been received, you will receive a second email, usually within 1-2 business hours, containing a download link for the firmware file. Click on this link and download the firmware file to your computer (PC only).

- d. The downloaded file will be in ZIP compressed format. Unzip this file to an empty directory (you can use a utility like Winzip, 7Zip, Winrar, etc.). Once un-compressed, you should see a file named *ATRT-03S2.HEX*. Copy this file to the root of a USB Flash drive.
- e. Make sure the ATRT-03 S2's power is OFF, and then insert the USB Flash drive containing the firmware file in the ATRT-03 S2's Flash drive port (labeled "USB MEM").
- f. While holding down the **[STOP]** key, turn on the unit.
- g. Continue to hold down the **[STOP]** key while the unit powers up.
- h. After the initial logo screen, the following screen will be displayed:



Continue to hold down the **[STOP]** key.

- i. The firmware upgrade process will start and the following screen will be displayed:

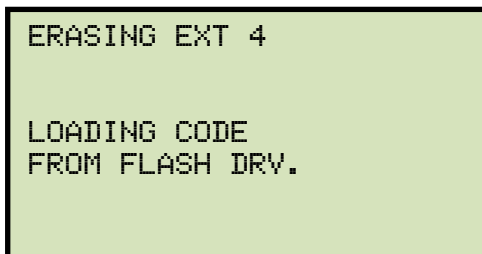

You can release the **[STOP]** key at this point. The ATRT-03 S2 will continue with the upgrade process and display the following screen:

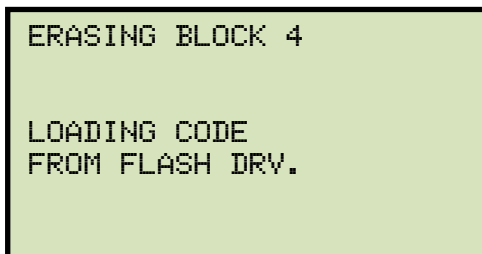

When the firmware upgrade has finished, the following screen will be displayed:

```
LOADING CODE  
FROM FLASH DRV.  
  
BOOT LDR R X.XX
```

You will hear a series of beeps as the unit re-boots. Once the unit has re-booted, the "START-UP" menu will be displayed. The upgraded unit is now ready for use.

<http://www.51082245.com>

APPENDIX A – TRANSFORMER VECTOR GROUP CODES

Utility power transformers manufactured in accordance with IEC specifications have a Rating Plate attached in a visible location. This plate contains a list of the transformer's configuration and operating specifications. One such rating is the winding configuration and phase-displacement code. This code follows a convention that comprises letter and number sets that denote three-phase winding configurations (i.e., Wye, delta, or zig-zag). Letter symbols for the different windings are noted in descending order of their rated voltages. That is, symbols denoting higher voltage ratings will be in upper-case letters and symbols denoting lower or intermediate voltage ratings will be in lower-case letters. If the neutral point of either a wye or zig-zag winding is brought out, the indication will be an N (high voltage) or n (lower voltage). The end numeral is a 300 multiplier that indicates phase lag between windings.

Accordingly, the following standard practice applies:

Wye (or star) = Y (high voltage) or y (low voltage)

Delta = D (high voltage) or d (low voltage)

Zig-zag = Z (high voltage) or z (low voltage)

For example, **Dyn11** decodes as follows:

D indicates that the high-voltage windings are connected in a Delta configuration (Since delta windings do not have a neutral point, the N never appears after a D).

y indicates that the lower voltage winding is in a wye (or star) configuration.

n indicates that the lower voltage windings have the neutral point brought out.

11 indicates a phase-displacement lag of 330 degrees between the Wye and the Delta winding.

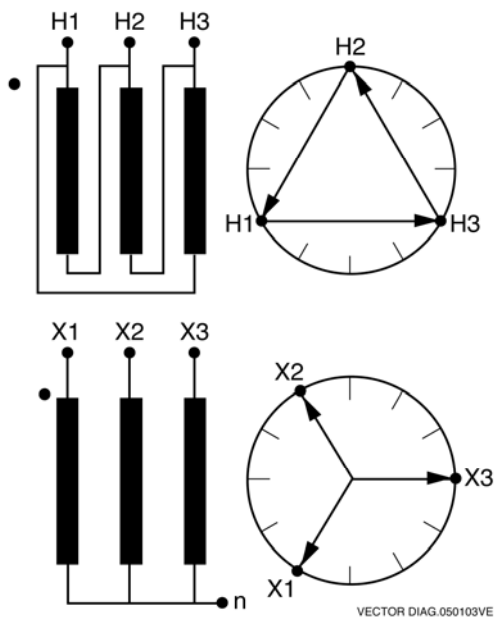

APPENDIX B – Common ANSI Transformer Descriptions

STD TEST NO.	TRANSFORMER CONFIGURATION		PHASE	WINDING TESTED		TURNS RATIO	VECTOR GROUP	NOTES
	HIGH-VOLTAGE WINDING (H)	LOW-VOLTAGE WINDING (X)		HIGH VOLTAGE WINDING	LOW VOLTAGE WINDING			
1			1 ∅	H ₁ - H ₂	X ₁ - X ₂	$\frac{V_H}{V_X}$	1ph0	SNG - PHS
2			A	H ₁ - H ₃	X ₁ - X ₀	$\frac{V_H \cdot \sqrt{3}}{V_X}$	Dyn1	dt - Y
			B	H ₂ - H ₁	X ₂ - X ₀			
			C	H ₃ - H ₂	X ₃ - X ₀			
3			A	H ₁ - H ₀	X ₁ - X ₂	$\frac{V_H}{V_X \cdot \sqrt{3}}$	YNd1	y - dt
			B	H ₂ - H ₀	X ₂ - X ₃			
			C	H ₃ - H ₀	X ₃ - X ₁			
4			A	H ₁ - H ₃	X ₁ - X ₃	$\frac{V_H}{V_X}$	Dd0	dt - dt
			B	H ₂ - H ₁	X ₂ - X ₁			
			C	H ₃ - H ₂	X ₃ - X ₂			
5			A	H ₁ - H ₀	X ₁ - X ₀	$\frac{V_H}{V_X}$	YNyn0	y - y
			B	H ₂ - H ₀	X ₂ - X ₀			
			C	H ₃ - H ₀	X ₃ - X ₀			

VANGUARD.050207V1

SPEC TEST NO.	TRANSFORMER CONFIGURATION		EXT. JUMPER	PHASE	WINDING TESTED		CAL. TURN RATIO	VECTOR GROUP	NOTES
	HIGH-VOLTAGE WINDING (H)	LOW-VOLTAGE WINDING (X)			HIGH VOLTAGE WINDING	LOW VOLTAGE WINDING			
1			—	A	H ₁ - H ₃	X ₃ - X ₁	$\frac{V_H}{V_X}$	Dd6	
				B	H ₂ - H ₁	X ₁ - X ₂			
				C	H ₃ - H ₂	X ₂ - X ₃			
37			—	A	H ₁ - H ₃	X ₁ - X ₃	$\frac{V_H}{V_X}$	Dd0	
				B	H ₂ - H ₁	X ₂ - X ₁			
				C	H ₃ - H ₂	X ₃ - X ₂			
38			—	A	H ₁ - H ₂	X ₃ - X ₂	$\frac{V_H}{V_X}$	Dd2	
				B	H ₂ - H ₃	X ₁ - X ₃			
				C	H ₃ - H ₁	X ₂ - X ₁			
39			—	A	H ₁ - H ₂	X ₃ - X ₁	$\frac{V_H}{V_X}$	Dd4	
				B	H ₂ - H ₃	X ₁ - X ₂			
				C	H ₃ - H ₁	X ₂ - X ₃			
40			—	A	H ₁ - H ₂	X ₂ - X ₃	$\frac{V_H}{V_X}$	Dd8	
				B	H ₂ - H ₃	X ₃ - X ₁			
				C	H ₃ - H ₁	X ₁ - X ₂			
41			—	A	H ₁ - H ₂	X ₁ - X ₃	$\frac{V_H}{V_X}$	Dd10	
				B	H ₂ - H ₃	X ₂ - X ₁			
				C	H ₃ - H ₁	X ₃ - X ₂			
42			—	A	H ₁ - H ₃	X ₁ - X ₀	$\frac{V_H \cdot \sqrt{3}}{V_X}$	Dyn1	
				B	H ₂ - H ₁	X ₂ - X ₀			
				C	H ₃ - H ₂	X ₃ - X ₀			
2			H ₃ -H ₂ H ₁ -H ₃ H ₂ -H ₁	A	H ₁ - H ₃	X ₁ - X ₃	$\frac{V_H \cdot \sqrt{3}}{V_X}$	Dy1	NO ACCESSIBLE NEUTRAL ON WYE WINDING
				B	H ₂ - H ₁	X ₂ - X ₁			
				C	H ₃ - H ₂	X ₃ - X ₂			
61			H ₃ -H ₂ H ₁ -H ₃ H ₂ -H ₁	A	H ₁ - H ₃	X ₁ - X ₂	$\frac{V_H \cdot \sqrt{3}}{V_X}$	Dy3	NO ACCESSIBLE NEUTRAL ON WYE WINDING
				B	H ₂ - H ₁	X ₂ - X ₃			
				C	H ₃ - H ₂	X ₃ - X ₁			
62			—	A	H ₁ - H ₃	X ₀ - X ₂	$\frac{V_H \cdot \sqrt{3}}{V_X}$	Dyn3	
				B	H ₂ - H ₁	X ₀ - X ₃			
				C	H ₃ - H ₂	X ₀ - X ₁			

VANGUARD.050108V1

SPEC TEST NO.	TRANSFORMER CONFIGURATION		EXT. JUMPER	PHASE	WINDING TESTED		CAL. TURN RATIO	VECTOR GROUP	NOTES
	HIGH-VOLTAGE WINDING (H)	LOW-VOLTAGE WINDING (X)			HIGH VOLTAGE WINDING	LOW VOLTAGE WINDING			
3			—	A	H1 - H3	X3 - X0	$\frac{V_H \cdot \sqrt{3}}{V_X}$	Dyn5	
				B	H2 - H1	X1 - X0			
				C	H3 - H2	X2 - X0			
4			H3-H2 H1-H3 H2-H1	A	H1 - H3	X3 - X2	$\frac{V_H \cdot \sqrt{3}}{V_X}$	Dy5	NO ACCESSIBLE NEUTRAL ON WYE WINDING
				B	H2 - H1	X1 - X3			
				C	H3 - H2	X2 - X1			
5			—	A	H1 - H3	X0 - X1	$\frac{V_H \cdot \sqrt{3}}{V_X}$	Dyn7	
				B	H2 - H1	X0 - X2			
				C	H3 - H2	X0 - X3			
6			H3-H2 H1-H3 H2-H1	A	H1 - H3	X3 - X1	$\frac{V_H \cdot \sqrt{3}}{V_X}$	Dy7	NO ACCESSIBLE NEUTRAL ON WYE WINDING
				B	H2 - H1	X1 - X2			
				C	H3 - H2	X2 - X3			
63			H3-H2 H1-H3 H2-H1	A	H1 - H3	X2 - X1	$\frac{V_H \cdot \sqrt{3}}{V_X}$	Dy9	NO ACCESSIBLE NEUTRAL ON WYE WINDING
				B	H2 - H1	X3 - X2			
				C	H3 - H2	X1 - X3			
64			—	A	H1 - H3	X2 - X0	$\frac{V_H \cdot \sqrt{3}}{V_X}$	Dyn9	
				B	H2 - H1	X3 - X0			
				C	H3 - H2	X1 - X0			
7			—	A	H1 - H3	X0 - X3	$\frac{V_H \cdot \sqrt{3}}{V_X}$	Dyn11	
				B	H2 - H1	X0 - X1			
				C	H3 - H2	X0 - X2			
8			H3-H2 H1-H3 H2-H1	A	H1 - H3	X2 - X3	$\frac{V_H \cdot \sqrt{3}}{V_X}$	Dy11	NO ACCESSIBLE NEUTRAL ON WYE WINDING
				B	H2 - H1	X3 - X1			
				C	H3 - H2	X1 - X2			
45			H2-H3 H3-H1 H1-H2	A	H1 - H2	X1 - X0	$\frac{3}{2} \cdot \frac{V_H}{V_X}$	Dzn0	
				B	H2 - H3	X2 - X0			
				C	H3 - H1	X3 - X0			
46			H2-H3 H3-H1 H1-H2	A	H1 - H2	X0 - X2	$\frac{3}{2} \cdot \frac{V_H}{V_X}$	Dzn2	
				B	H2 - H3	X0 - X3			
				C	H3 - H1	X0 - X1			

VANGUARD.050108V2

SPEC TEST NO.	TRANSFORMER CONFIGURATION		EXT. JUMPER	PHASE	WINDING TESTED		CAL. TURN RATIO	VECTOR GROUP	NOTES
	HIGH-VOLTAGE WINDING (H)	LOW-VOLTAGE WINDING (X)			HIGH VOLTAGE WINDING	LOW VOLTAGE WINDING			
47			—	A	H1 - H2	X3 - X2	$\frac{V_H}{V_X}$	Dz2	NO ACCESSIBLE NEUTRAL
				B	H2 - H3	X1 - X3			
				C	H3 - H1	X2 - X1			
48			H2-H3 H3-H1 H1-H2	A	H1 - H2	X3 - X0	$\frac{3}{2} \cdot \frac{V_H}{V_X}$	Dzn4	
				B	H2 - H3	X1 - X0			
				C	H3 - H1	X2 - X0			
49			—	A	H1 - H2	X3 - X1	$\frac{V_H}{V_X}$	Dz4	NO ACCESSIBLE NEUTRAL
				B	H2 - H3	X1 - X2			
				C	H3 - H1	X2 - X3			
9			—	A	H1 - H3	X1 - X3	$\frac{V_H}{V_X}$	Dz0	NO ACCESSIBLE NEUTRAL
				B	H2 - H1	X2 - X1			
				C	H3 - H2	X3 - X2			
10			—	A	H1 - H3	X3 - X1	$\frac{V_H}{V_X}$	Dz6	NO ACCESSIBLE NEUTRAL
				B	H2 - H1	X1 - X2			
				C	H3 - H2	X2 - X3			
50			H2-H3 H3-H1 H1-H2	A	H1 - H2	X0 - X1	$\frac{3}{2} \cdot \frac{V_H}{V_X}$	Dzn6	
				B	H2 - H3	X0 - X2			
				C	H3 - H1	X0 - X3			
51			H2-H3 H3-H1 H1-H2	A	H1 - H2	X2 - X0	$\frac{3}{2} \cdot \frac{V_H}{V_X}$	Dzn8	
				B	H2 - H3	X3 - X0			
				C	H3 - H1	X1 - X0			
52			—	A	H1 - H2	X2 - X3	$\frac{V_H}{V_X}$	Dz8	NO ACCESSIBLE NEUTRAL
				B	H2 - H3	X3 - X1			
				C	H3 - H1	X1 - X2			
53			H2-H3 H3-H1 H1-H2	A	H1 - H2	X0 - X3	$\frac{3}{2} \cdot \frac{V_H}{V_X}$	Dzn10	
				B	H2 - H3	X0 - X1			
				C	H3 - H1	X0 - X2			
54			—	A	H1 - H2	X1 - X3	$\frac{V_H}{V_X}$	Dz10	NO ACCESSIBLE NEUTRAL
				B	H2 - H3	X2 - X1			
				C	H3 - H1	X3 - X2			

VANGUARD.050108V3

SPEC TEST NO.	TRANSFORMER CONFIGURATION		EXT. JUMPER	PHASE	WINDING TESTED		CAL. TURN RATIO	VECTOR GROUP	NOTES
	HIGH-VOLTAGE WINDING (H)	LOW-VOLTAGE WINDING (X)			HIGH VOLTAGE WINDING	LOW VOLTAGE WINDING			
11			—	A	H1 - H0	X2 - X1	$\frac{V_H}{V_X \cdot \sqrt{3}}$	YNd7	
				B	H2 - H0	X3 - X2			
				C	H3 - H0	X1 - X3			
44			—	A	H1 - H0	X1 - X2	$\frac{V_H}{V_X \cdot \sqrt{3}}$	YNd1	
				B	H2 - H0	X2 - X3			
				C	H3 - H0	X3 - X1			
12			H3-H2	A	H1 - H3	X1 - X2	$\frac{V_H \cdot \sqrt{3}}{V_X \cdot 2}$	Yd1	NO ACCESSIBLE NEUTRAL ON WYE WINDING
			H1-H3	B	H2 - H1	X2 - X3			
			H2-H1	C	H3 - H2	X3 - X1			
13			—	A	H1 - H0	X3 - X2	$\frac{V_H}{V_X \cdot \sqrt{3}}$	YNd5	
				B	H2 - H0	X1 - X2			
				C	H3 - H0	X2 - X3			
14			H3-H2	A	H1 - H3	X3 - X1	$\frac{V_H \cdot \sqrt{3}}{V_X \cdot 2}$	Yd5	NO ACCESSIBLE NEUTRAL ON WYE WINDING
			H1-H3	B	H2 - H1	X1 - X2			
			H2-H1	C	H3 - H2	X2 - X3			
15			H3-H2	A	H1 - H3	X2 - X1	$\frac{V_H \cdot \sqrt{3}}{V_X \cdot 2}$	Yd7	NO ACCESSIBLE NEUTRAL ON WYE WINDING
			H1-H3	B	H2 - H1	X3 - X2			
			H2-H1	C	H3 - H2	X1 - X3			
16			—	A	H1 - H0	X1 - X3	$\frac{V_H}{V_X \cdot \sqrt{3}}$	YNd11	
				B	H2 - H0	X2 - X1			
				C	H3 - H0	X3 - X2			
17			H3-H2	A	H1 - H3	X1 - X3	$\frac{V_H \cdot \sqrt{3}}{V_X \cdot 2}$	Yd11	NO ACCESSIBLE NEUTRAL ON WYE WINDING
			H1-H3	B	H2 - H1	X2 - X1			
			H2-H1	C	H3 - H2	X3 - X2			
18			—	A	H1 - H0	X0 - X1	$\frac{V_H}{V_X}$	YNyn6	
				B	H2 - H0	X0 - X2			
				C	H3 - H0	X0 - X3			
19			H2-H0	A	H1 - H0	X1 - X2	$\frac{V_H}{V_X}$	YNy0	NO ACCESSIBLE NEUTRAL ON LOW VOLTAGE WINDING
			H3-H0	B	H2 - H0	X2 - X3			
			H1-H0	C	H3 - H0	X3 - X1			

VANGUARD.050108V4

SPEC TEST NO.	TRANSFORMER CONFIGURATION		EXT. JUMPER	PHASE	WINDING TESTED		CAL. TURN RATIO	VECTOR GROUP	NOTES
	HIGH-VOLTAGE WINDING (H)	LOW-VOLTAGE WINDING (X)			HIGH VOLTAGE WINDING	LOW VOLTAGE WINDING			
20			X ₃ -X ₀ X ₁ -X ₀ X ₂ -X ₀	A	H ₁ - H ₃	X ₁ - X ₀	$\frac{V_H}{V_x}$	Yyn0	NO ACCESSIBLE NEUTRAL ON HIGH VOLTAGE WINDING
				B	H ₂ - H ₁	X ₂ - X ₀			
				C	H ₃ - H ₂	X ₃ - X ₀			
43			—	A	H ₁ - H ₀	X ₁ - X ₀	$\frac{V_H}{V_L}$	YNyn0	
				B	H ₂ - H ₀	X ₂ - X ₀			
				C	H ₃ - H ₀	X ₃ - X ₀			
21			—	A	H ₁ - H ₃	X ₁ - X ₃	$\frac{V_H}{V_x}$	Yy0	NO ACCESSIBLE NEUTRAL
				B	H ₂ - H ₁	X ₂ - X ₁			
				C	H ₃ - H ₂	X ₃ - X ₂			
22			H ₂ -H ₀ H ₃ -H ₀ H ₁ -H ₀	A	H ₁ - H ₀	X ₂ - X ₁	$\frac{V_H}{V_x}$	YNy6	NO ACCESSIBLE NEUTRAL ON LOW VOLTAGE WINDING
				B	H ₂ - H ₀	X ₃ - X ₂			
				C	H ₃ - H ₀	X ₁ - X ₃			
23			X ₃ -X ₀ X ₁ -X ₀ X ₂ -X ₀	A	H ₁ - H ₃	X ₀ - X ₁	$\frac{V_H}{V_x}$	Yyn6	NO ACCESSIBLE NEUTRAL ON HIGH VOLTAGE WINDING
				B	H ₂ - H ₁	X ₀ - X ₂			
				C	H ₃ - H ₂	X ₀ - X ₃			
24			—	A	H ₁ - H ₃	X ₃ - X ₁	$\frac{V_H}{V_x}$	Yy6	NO ACCESSIBLE NEUTRAL
				B	H ₂ - H ₁	X ₁ - X ₂			
				C	H ₃ - H ₂	X ₂ - X ₃			
65			—	A	H ₁ - H ₃	X ₁ - X ₀	$\frac{V_H \cdot \sqrt{3}}{V_x}$	YNzn1	
				B	H ₂ - H ₁	X ₂ - X ₀			
				C	H ₃ - H ₂	X ₃ - X ₀			
25			—	A	H ₁ - H ₃	X ₁ - X ₀	$\frac{V_H \cdot \sqrt{3}}{V_x}$	Yzn1	NO ACCESSIBLE NEUTRAL ON WYE WINDING
				B	H ₂ - H ₁	X ₂ - X ₀			
				C	H ₃ - H ₂	X ₃ - X ₀			
26			H ₃ -H ₂ H ₁ -H ₃ H ₂ -H ₁	A	H ₁ - H ₃	X ₁ - X ₂	$\frac{V_H \cdot \sqrt{3}}{V_x \cdot 2}$	Yz1	NO ACCESSIBLE NEUTRAL
				B	H ₂ - H ₁	X ₂ - X ₃			
				C	H ₃ - H ₂	X ₃ - X ₁			
27			—	A	H ₁ - H ₃	X ₃ - X ₀	$\frac{V_H \cdot \sqrt{3}}{V_x}$	Yzn5	NO ACCESSIBLE NEUTRAL ON WYE WINDING
				B	H ₂ - H ₁	X ₁ - X ₀			
				C	H ₃ - H ₂	X ₂ - X ₀			

VANGUARD.050108V5

SPEC TEST NO.	TRANSFORMER CONFIGURATION		EXT. JUMPER	PHASE	WINDING TESTED		CAL. TURN RATIO	VECTOR GROUP	NOTES
	HIGH-VOLTAGE WINDING (H)	LOW-VOLTAGE WINDING (X)			HIGH VOLTAGE WINDING	LOW VOLTAGE WINDING			
28			H3-H2 H1-H3 H2-H1	A	H1 - H3	X3 - X1	$\frac{V_H \cdot \sqrt{3}}{V_X \cdot 2}$	Yz5	NO ACCESSIBLE NEUTRAL
				B	H2 - H1	X1 - X2			
				C	H3 - H2	X2 - X3			
66			—	A	H1 - H3	X0 - X1	$\frac{V_H \cdot \sqrt{3}}{V_X}$	YNzn7	
				B	H2 - H1	X0 - X2			
				C	H3 - H2	X0 - X3			
29			—	A	H1 - H3	X0 - X1	$\frac{V_H \cdot \sqrt{3}}{V_X}$	Yzn7	NO ACCESSIBLE NEUTRAL ON WYE WINDING
				B	H2 - H1	X0 - X2			
				C	H3 - H2	X0 - X3			
30			H3-H2 H1-H3 H2-H1	A	H1 - H3	X2 - X1	$\frac{V_H \cdot \sqrt{3}}{V_X \cdot 2}$	Yz7	NO ACCESSIBLE NEUTRAL
				B	H2 - H1	X3 - X2			
				C	H3 - H2	X1 - X3			
67			—	A	H1 - H3	X0 - X3	$\frac{V_H \cdot \sqrt{3}}{V_X}$	YNzn11	
				B	H2 - H1	X0 - X1			
				C	H3 - H2	X0 - X2			
31			—	A	H1 - H3	X0 - X3	$\frac{V_H \cdot \sqrt{3}}{V_X}$	Yzn11	NO ACCESSIBLE NEUTRAL ON WYE WINDING
				B	H2 - H1	X0 - X1			
				C	H3 - H2	X0 - X2			
32			H3-H2 H1-H3 H2-H1	A	H1 - H3	X1 - X3	$\frac{V_H \cdot \sqrt{3}}{V_X \cdot 2}$	Yz11	NO ACCESSIBLE NEUTRAL
				B	H2 - H1	X2 - X1			
				C	H3 - H2	X3 - X2			
55			X2-X3 X3-X1 X1-X2	A	H1 - H0	X1 - X2	$\frac{2}{3} \cdot \frac{V_H}{V_X}$	ZNd0	
				B	H2 - H0	X2 - X3			
				C	H3 - H0	X3 - X1			
56			—	A	H1 - H2	X1 - X2	$\frac{V_H}{V_X}$	Zd0	NO ACCESSIBLE NEUTRAL ON HIGH VOLTAGE
				B	H2 - H3	X2 - X3			
				C	H3 - H1	X3 - X1			
57			X2-X3 X3-X1 X1-X2	A	H1 - H0	X2 - X1	$\frac{2}{3} \cdot \frac{V_H}{V_X}$	ZNd6	
				B	H2 - H0	X3 - X2			
				C	H3 - H0	X1 - X3			

SPEC TEST NO.	TRANSFORMER CONFIGURATION		EXT. JUMPER	PHASE	WINDING TESTED		CAL. TURN RATIO	VECTOR GROUP	NOTES
	HIGH-VOLTAGE WINDING (H)	LOW-VOLTAGE WINDING (X)			HIGH VOLTAGE WINDING	LOW VOLTAGE WINDING			
33		—	A	H1 - H0	X3 - X1	$\frac{V_H}{V_X \cdot \sqrt{3}}$	ZNy5	NO ACCESSIBLE NEUTRAL ON WYE WINDING	
			B	H2 - H0	X1 - X2				
			C	H3 - H0	X2 - X3				
34		H3-H2 H1-H3 H2-H1	A	H1 - H3	X3 - X1	$\frac{V_H \cdot \sqrt{3}}{V_X \cdot 2}$	Zy5	NO ACCESSIBLE NEUTRAL	
			B	H2 - H1	X1 - X2				
			C	H3 - H2	X2 - X3				
35		—	A	H1 - H0	X1 - X3	$\frac{V_H}{V_X \cdot \sqrt{3}}$	ZNy11	NO ACCESSIBLE NEUTRAL ON WYE WINDING	
			B	H2 - H0	X2 - X1				
			C	H3 - H0	X3 - X2				
36		H3-H2 H1-H3 H2-H1	A	H1 - H3	X1 - X3	$\frac{V_H \cdot \sqrt{3}}{V_X \cdot 2}$	Zy11	NO ACCESSIBLE NEUTRAL	
			B	H2 - H1	X2 - X1				
			C	H3 - H2	X3 - X2				
58		H1-H2 X1-X2	A	H1 - H2	X1 - X2	$\frac{V_H}{V_X}$	T-T 0		
			B	H1 - H3	X1 - X3				
59		H2-H3 X1-X2	A	H1 - H3	X1 - X2	$\frac{V_H \cdot \sqrt{3}}{V_X \cdot 2}$	T-T 30 Lag		
			B	H2 - H3	X1 - X3	$\frac{V_H \cdot 2}{V_X \cdot \sqrt{3}}$			
60		H2-H3 X1-X3	A	H1 - H3	X1 - X3	$\frac{V_H \cdot \sqrt{3}}{V_X \cdot 2}$	T-T 30 Lead		
			B	H2 - H3	X2 - X1	$\frac{V_X \cdot 2}{V_H \cdot \sqrt{3}}$			

VANGUARD.050108V7

APPENDIX C – CEI/IEC 60076-1 Transformer Descriptions

SPEC TEST NO.	TRANSFORMER CONFIGURATION		EXT. JUMPER	PHASE	WINDING TESTED		CAL. TURN RATIO	VECTOR GROUP	NOTES
	HIGH-VOLTAGE WINDING (H)	LOW-VOLTAGE WINDING (X)			HIGH VOLTAGE WINDING	LOW VOLTAGE WINDING			
1			—	A	1U – 1W	2W – 2U	$\frac{U_1}{U_2}$	Dd6	
				B	1V – 1U	2U – 2V			
				C	1W – 1V	2V – 2W			
37			—	A	1U – 1W	2U – 2W	$\frac{U_1}{U_2}$	Dd0	
				B	1V – 1U	2V – 2U			
				C	1W – 1V	2W – 2V			
38			—	A	1U – 1V	2W – 2V	$\frac{U_1}{U_2}$	Dd2	
				B	1V – 1W	2U – 2W			
				C	1W – 1U	2V – 2U			
39			—	A	1U – 1W	2W – 2U	$\frac{U_1}{U_2}$	Dd4	
				B	1V – 1U	2U – 2V			
				C	1W – 1U	2V – 2W			
40			—	A	1U – 1V	2V – 2W	$\frac{U_1}{U_2}$	Dd8	
				B	1V – 1W	2W – 2U			
				C	1W – 1U	2U – 2V			
41			—	A	1U – 1V	2U – 2W	$\frac{U_1}{U_2}$	Dd10	
				B	1V – 1W	2V – 2U			
				C	1W – 1U	2W – 2V			
42			—	A	1U – 1W	2U – 2N	$\frac{U_1 \cdot \sqrt{3}}{U_2}$	Dyn1	
				B	1V – 1U	2V – 2N			
				C	1W – 1V	2W – 2N			
2			1W – 1V 1U – 1W 1V – 1U	A	1U – 1W	2U – 2V	$\frac{U_1 \cdot \sqrt{3}}{U_2}$	Dy1	NO ACCESSIBLE NEUTRAL ON WYE WINDING
				B	1V – 1U	2V – 2W			
				C	1W – 1V	2W – 2U			
61			1W – 1V 1U – 1W 1V – 1U	A	1U – 1W	2U – 2V	$\frac{\sqrt{3} U_1}{U_2}$	Dy3	NO ACCESSIBLE NEUTRAL ON WYE WINDING
				B	1V – 1U	2V – 2W			
				C	1W – 1V	2W – 2U			
62			—	A	1U – 1W	2N – 2V	$\frac{U_1 \cdot \sqrt{3}}{U_2}$	Dyn3	
				B	1V – 1U	2N – 2W			
				C	1W – 1V	2N – 2U			

CEI/IEC.050108C1

SPEC TEST NO.	TRANSFORMER CONFIGURATION		EXT. JUMPER	PHASE	WINDING TESTED		CAL. TURN RATIO	VECTOR GROUP	NOTES
	HIGH-VOLTAGE WINDING (H)	LOW-VOLTAGE WINDING (X)			HIGH VOLTAGE WINDING	LOW VOLTAGE WINDING			
3			—	A	1U-1W	2W-2N	$\frac{U_1 \cdot \sqrt{3}}{U_2}$	Dyn5	
				B	1V-1U	2U-2N			
				C	1W-1V	2V-2N			
4			1W-1V	A	1U-1W	2W-2V	$\frac{U_1 \cdot \sqrt{3}}{U_2}$	Dy5	NO ACCESSIBLE NEUTRAL ON WYE WINDING
			1U-1W	B	1V-1U	2U-2W			
			1V-1U	C	1W-1V	2V-2U			
5			—	A	1U-1W	2N-2U	$\frac{U_1 \cdot \sqrt{3}}{U_2}$	Dyn7	
			B	1V-1U	2V-2W				
			C	1W-1V	2N-2W				
6			1W-1V	A	1U-1W	2W-2U	$\frac{U_1 \cdot \sqrt{3}}{U_2}$	Dy7	NO ACCESSIBLE NEUTRAL ON WYE WINDING
			1U-1W	B	1V-1U	2U-2V			
			1V-1U	C	1W-1V	2V-2W			
63			1W-1V	A	1U-1W	2V-2U	$\frac{U_1 \cdot \sqrt{3}}{U_2}$	Dy9	NO ACCESSIBLE NEUTRAL ON WYE WINDING
			1U-1W	B	1V-1U	2W-2V			
			1V-1U	C	1W-1V	2U-2W			
64			—	A	1U-1W	2V-2N	$\frac{U_1 \cdot \sqrt{3}}{U_2}$	Dyn9	
			B	1V-1U	2W-2N				
			C	1W-1V	2U-2N				
7			—	A	1U-1W	2N-2W	$\frac{U_1 \cdot \sqrt{3}}{U_2}$	Dyn11	
			B	1V-1U	2N-2U				
			C	1W-1V	2N-2V				
8			1W-1V	A	1U-1W	2V-2W	$\frac{U_1 \cdot \sqrt{3}}{U_2}$	Dy11	NO ACCESSIBLE NEUTRAL ON WYE WINDING
			1U-1W	B	1V-1U	2W-2U			
			1V-1U	C	1W-1V	2U-2V			
45			1V-1W	A	1U-1V	2U-2N	$\frac{3}{2} \cdot \frac{U_1}{U_2}$	Dzn0	
			1W-1U	B	1V-1W	2V-2N			
			1U-1V	C	1W-1U	2W-2N			
46			1V-1W	A	1U-1V	2N-2V	$\frac{3}{2} \cdot \frac{U_1}{U_2}$	Dzn2	
			1W-1U	B	1V-1W	2N-2W			
			1U-1V	C	1W-1U	2N-2U			

CEI/IEC.050108C2

SPEC TEST NO.	TRANSFORMER CONFIGURATION		EXT. JUMPER	PHASE	WINDING TESTED		CAL. TURN RATIO	VECTOR GROUP	NOTES
	HIGH-VOLTAGE WINDING (H)	LOW-VOLTAGE WINDING (X)			HIGH VOLTAGE WINDING	LOW VOLTAGE WINDING			
47			—	A	1U – 1V	2W – 2V	$\frac{U_1}{U_2}$	Dz2	NO ACCESSIBLE NEUTRAL
				B	1V – 1W	2U – 2W			
				C	1W – 1U	2V – 2U			
48			1V-1W	A	1U – 1V	2W – 2N	$\frac{3}{2} \cdot \frac{U_1}{U_2}$	Dzn4	
			1W-1U	B	1V – 1W	2U – 2N			
			1U-1V	C	1W – 1U	2V – 2N			
49			—	A	1U – 1V	2W – 2U	$\frac{U_1}{U_2}$	Dz4	NO ACCESSIBLE NEUTRAL
				B	1V – 1W	2U – 2V			
				C	1W – 1U	2V – 2W			
9			—	A	1U – 1W	2U – 2W	$\frac{U_1}{U_2}$	Dz0	NO ACCESSIBLE NEUTRAL
				B	1V – 1U	2V – 2U			
				C	1W – 1V	2W – 2V			
10			—	A	1U – 1W	2W – 2U	$\frac{U_1}{U_2}$	Dz6	NO ACCESSIBLE NEUTRAL
				B	1V – 1U	2U – 2V			
				C	1W – 1V	2V – 2W			
50			1V-1W	A	1U – 1V	2N – 2U	$\frac{3}{2} \cdot \frac{U_1}{U_2}$	Dzn6	
			1W-1U	B	1V – 1W	2N – 2V			
			1U-1V	C	1W – 1U	2N – 2W			
51			1V-1W	A	1U – 1V	2V – 2N	$\frac{3}{2} \cdot \frac{U_1}{U_2}$	Dzn8	
			1W-1U	B	1V – 1W	2W – 2N			
			1U-1V	C	1W – 1U	2U – 2N			
52			—	A	1U – 1V	2V – 2W	$\frac{U_1}{U_2}$	Dz8	NO ACCESSIBLE NEUTRAL
				B	1V – 1W	2W – 2U			
				C	1W – 1U	2U – 2V			
53			1V-1W	A	1U – 1V	2N – 2W	$\frac{3}{2} \cdot \frac{U_1}{U_2}$	Dzn10	
			1W-1U	B	1V – 1W	2N – 2U			
			1U-1V	C	1W – 1U	2N – 2V			
54			—	A	1U – 1V	2U – 2W	$\frac{U_1}{U_2}$	Dz10	NO ACCESSIBLE NEUTRAL
				B	1V – 1W	2V – 2U			
				C	1W – 1U	2W – 2V			

CEI/IEC.050108C3

SPEC TEST NO.	TRANSFORMER CONFIGURATION		EXT. JUMPER	PHASE	WINDING TESTED		CAL. TURN RATIO	VECTOR GROUP	NOTES
	HIGH-VOLTAGE WINDING (H)	LOW-VOLTAGE WINDING (X)			HIGH VOLTAGE WINDING	LOW VOLTAGE WINDING			
11			—	A	1U – 1N	2V – 2U	$\frac{U_1}{U_2 \cdot \sqrt{3}}$	YNd7	
				B	1V – 1N	2W – 2V			
				C	1W – 1N	2U – 2W			
44			—	A	1U – 1N	2U – 2V	$\frac{U_1}{U_2 \cdot \sqrt{3}}$	YNd1	
				B	1V – 1N	2V – 2W			
				C	1W – 1N	2W – 2U			
12			1W-1V	A	1U – 1W	2U – 2V	$\frac{U_1 \cdot \sqrt{3}}{U_2 \cdot 2}$	Yd1	NO ACCESSIBLE NEUTRAL ON WYE WINDING
			1U-1W	B	1V – 1U	2V – 2W			
			1V-1U	C	1W – 1V	2W – 2U			
13			—	A	1U – 1N	2W – 2U	$\frac{U_1}{U_2 \cdot \sqrt{3}}$	YNd5	
				B	1V – 1N	2U – 2V			
				C	1W – 1N	2V – 2W			
14			1W-1V	A	1U – 1W	2W – 2U	$\frac{U_1 \cdot \sqrt{3}}{U_2 \cdot 2}$	Yd5	NO ACCESSIBLE NEUTRAL ON WYE WINDING
			1U-1W	B	1V – 1U	2U – 2V			
			1V-1U	C	1W – 1V	2V – 2W			
15			1W-1V	A	1U – 1W	2V – 2U	$\frac{U_1 \cdot \sqrt{3}}{U_2 \cdot 2}$	Yd7	NO ACCESSIBLE NEUTRAL ON WYE WINDING
			1U-1W	B	1V – 1U	2W – 2V			
			1V-1U	C	1W – 1V	2U – 2W			
16			—	A	1U – 1N	2U – 2W	$\frac{U_1}{U_2 \cdot \sqrt{3}}$	YNd11	
				B	1V – 1N	2V – 2U			
				C	1W – 1N	2W – 2V			
17			1W-1V	A	1U – 1W	2U – 2W	$\frac{U_1 \cdot \sqrt{3}}{U_2 \cdot 2}$	Yd11	NO ACCESSIBLE NEUTRAL ON WYE WINDING
			1U-1W	B	1V – 1U	2V – 2U			
			1V-1U	C	1W – 1V	2W – 2V			
18			—	A	1U – 1N	2N – 2U	$\frac{U_1}{U_2}$	YNyn6	
				B	1V – 1N	2N – 2V			
				C	1W – 1N	2N – 2W			
19			1V-1N	A	1U – 1N	2U – 2V	$\frac{U_1}{U_2}$	YNy0	NO ACCESSIBLE NEUTRAL ON LOW VOLTAGE WINDING
			1W-1N	B	1V – 1N	2V – 2W			
			1U-1N	C	1W – 1N	2W – 2U			

CEI/IEC.050108C4

SPEC TEST NO.	TRANSFORMER CONFIGURATION		EXT. JUMPER	PHASE	WINDING TESTED		CAL. TURN RATIO	VECTOR GROUP	NOTES
	HIGH-VOLTAGE WINDING (H)	LOW-VOLTAGE WINDING (X)			HIGH VOLTAGE WINDING	LOW VOLTAGE WINDING			
20			2W-2N 2U-2N 2V-2N	A	1U-1W	2U-2N	$\frac{U_1}{U_2}$	Yyn0	NO ACCESSIBLE NEUTRAL ON HIGH VOLTAGE WINDING
				B	1V-1U	2V-2N			
				C	1W-1V	2W-2N			
43			—	A	1U-1N	2U-2W	$\frac{U_1}{U_2}$	YNyn0	
				B	1V-1N	2V-2N			
				C	1W-1N	2W-2N			
21			—	A	1U-1W	2U-2W	$\frac{U_1}{U_2}$	Yy0	NO ACCESSIBLE NEUTRAL
				B	1V-1U	2V-2U			
				C	1W-1V	2W-2V			
22			1V-1N 1W-1N 1U-1N	A	1U-1N	2V-2U	$\frac{U_1}{U_2}$	YNy6	NO ACCESSIBLE NEUTRAL ON LOW VOLTAGE WINDING
				B	1V-1N	2W-2V			
				C	1W-1N	2U-2W			
23			2W-2N 2U-2N 2V-2N	A	1U-1W	2N-2U	$\frac{U_1}{U_2}$	Yyn6	NO ACCESSIBLE NEUTRAL ON HIGH VOLTAGE WINDING
				B	1V-1U	2N-2V			
				C	1W-1V	2N-2W			
24			—	A	1U-1W	2W-2U	$\frac{U_1}{U_2}$	Yy6	NO ACCESSIBLE NEUTRAL
				B	1V-1U	2U-2V			
				C	1W-1V	2V-2W			
65			—	A	1U-1W	2U-2N	$\frac{V_H \cdot \sqrt{3}}{V_x}$	YNzn1	
				B	1V-1U	2V-2N			
				C	1W-1V	2W-2N			
25			—	A	1U-1W	2U-2N	$\frac{U_1 \cdot \sqrt{3}}{U_2}$	Yzn1	NO ACCESSIBLE NEUTRAL ON WYE WINDING
				B	1V-1U	2V-2N			
				C	1W-1V	2W-2N			
26			1W-1V 1U-1W 1V-1U	A	1U-1W	2U-2V	$\frac{U_1 \cdot \sqrt{3}}{U_2 \cdot 2}$	Yz1	NO ACCESSIBLE NEUTRAL
				B	1V-1U	2V-2W			
				C	1W-1V	2W-2U			
27			—	A	1U-1W	2W-2N	$\frac{U_1 \cdot \sqrt{3}}{U_2}$	Yzn5	NO ACCESSIBLE NEUTRAL ON WYE WINDING
				B	1V-1U	2U-2N			
				C	1W-1V	2V-2N			

CEI/IEC.050108C5

SPEC TEST NO.	TRANSFORMER CONFIGURATION		EXT. JUMPER	PHASE	WINDING TESTED		CAL. TURN RATIO	VECTOR GROUP	NOTES
	HIGH-VOLTAGE WINDING (H)	LOW-VOLTAGE WINDING (X)			HIGH VOLTAGE WINDING	LOW VOLTAGE WINDING			
28			1W-1V 1U-1W 1V-1U	A	1U - 1W	2W - 2U	$\frac{U_1 \cdot \sqrt{3}}{U_2 \cdot 2}$	Yz5	NO ACCESSIBLE NEUTRAL
				B	1V - 1U	2U - 2V			
				C	1W - 1V	2V - 2W			
66			—	A	1U - 1W	2N - 2U	$\frac{V_H \cdot \sqrt{3}}{V_X}$	YNzn7	
				B	1V - 1U	2N - 2V			
				C	1W - 1V	2N - 2W			
29			—	A	1U - 1W	2N - 2U	$\frac{U_1 \cdot \sqrt{3}}{U_2}$	Yzn7	NO ACCESSIBLE NEUTRAL ON WYE WINDING
				B	1V - 1U	2N - 2V			
				C	1W - 1V	2N - 2W			
30			1W-1V 1U-1W 1V-1U	A	1U - 1W	2V - 2U	$\frac{U_1 \cdot \sqrt{3}}{U_2 \cdot 2}$	Yz7	NO ACCESSIBLE NEUTRAL
				B	1V - 1U	2W - 2V			
				C	1W - 1V	2U - 2W			
67			—	A	1U - 1W	2N - 2W	$\frac{V_H \cdot \sqrt{3}}{V_X}$	YNzn11	
				B	1V - 1U	2N - 2U			
				C	1W - 1V	2N - 2V			
31			—	A	1U - 1W	2N - 2W	$\frac{U_1 \cdot \sqrt{3}}{U_2}$	Yzn11	NO ACCESSIBLE NEUTRAL ON WYE WINDING
				B	1V - 1U	2N - 2U			
				C	1W - 1V	2N - 2V			
32			1W-1V 1U-1W 1V-1U	A	1U - 1W	2U - 2W	$\frac{U_1 \cdot \sqrt{3}}{U_2 \cdot 2}$	Yz11	NO ACCESSIBLE NEUTRAL
				B	1V - 1U	2V - 2U			
				C	1W - 1V	2W - 2V			
55			1V-1W 1W-1U 1U-1V	A	1U - 1N	2U - 2V	$\frac{2}{3} \cdot \frac{U_1}{U_2}$	ZNd0	
				B	1V - 1N	2V - 2W			
				C	1W - 1N	2W - 2U			
56			—	A	1U - 1V	2U - 2V	$\frac{U_1}{U_2}$	Zd0	NO ACCESSIBLE NEUTRAL ON HIGH VOLTAGE
				B	1V - 1W	2V - 2W			
				C	1W - 1U	2W - 2U			
57			1V-1W 1W-1U 1U-1V	A	1U - 1N	2V - 2U	$\frac{2}{3} \cdot \frac{U_1}{U_2}$	ZNd6	
				B	1V - 1N	2W - 2V			
				C	1W - 1N	2U - 2W			

CEI/IEC.050108C6

SPEC TEST NO.	TRANSFORMER CONFIGURATION		EXT. JUMPER	PHASE	WINDING TESTED		CAL. TURN RATIO	VECTOR GROUP	NOTES
	HIGH-VOLTAGE WINDING (H)	LOW-VOLTAGE WINDING (X)			HIGH VOLTAGE WINDING	LOW VOLTAGE WINDING			
33			—	A	1U – 1N	2W – 2U	$\frac{U_1}{U_2 \cdot \sqrt{3}}$	ZNy5	NO ACCESSIBLE NEUTRAL ON WYE WINDING
				B	1V – 1N	2U – 2V			
				C	1W – 1N	2V – 2W			
34			1W–1V 1U–1W 1V–1U	A	1U – 1W	2W – 2U	$\frac{U_1 \cdot \sqrt{3}}{U_2 \cdot 2}$	Zy5	NO ACCESSIBLE NEUTRAL
				B	1V – 1U	2U – 2V			
				C	1W – 1V	2V – 2W			
35			—	A	1U – 1N	2U – 2W	$\frac{U_1}{U_2 \cdot \sqrt{3}}$	ZNy11	NO ACCESSIBLE NEUTRAL ON WYE WINDING
				B	1V – 1N	2V – 2U			
				C	1W – 1N	2W – 2V			
36			1W–1V 1U–1W 1V–1U	A	1U – 1W	2U – 2W	$\frac{U_1 \cdot \sqrt{3}}{U_2 \cdot 2}$	Zy11	NO ACCESSIBLE NEUTRAL
				B	1V – 1U	2V – 2U			
				C	1W – 1V	2W – 2V			
58			—	A	1U – 1V	2U – 2V	$\frac{U_1}{U_2}$	T-T 0	
				B	1U – 1W	2U – 2W			
59			1V–1W 2U–2V	A	1U – 1W	2U – 2V	$\frac{U_1 \cdot \sqrt{3}}{U_2 \cdot 2}$	T-T 30 Lag	
				B	1V – 1W	2U – 2W			
60			1V–1W 2U–2W	A	1U – 1W	2U – 2W	$\frac{U_1 \cdot \sqrt{3}}{U_2 \cdot 2}$	T-T 30 Lead	
				B	1V – 1W	2V – 2U			

CEI/IEC.050108C7

APPENDIX D – Australian Std.2374 Transformer Descriptions

SPEC TEST NO.	TRANSFORMER CONFIGURATION		EXT. JUMPER	PHASE	WINDING TESTED		CAL. TURN RATIO	VECTOR GROUP	NOTES
	HIGH-VOLTAGE WINDING (H)	LOW-VOLTAGE WINDING (X)			HIGH VOLTAGE WINDING	LOW VOLTAGE WINDING			
1			—	A	A - C	c - a	$\frac{HV}{LV}$	Dd6	
				B	B - A	a - b			
				C	C - B	b - c			
37			—	A	A - C	a - c	$\frac{HV}{LV}$	Dd0	
				B	B - A	b - a			
				C	C - B	c - b			
38			—	A	A - B	c - b	$\frac{HV}{LV}$	Dd2	
				B	B - C	a - c			
				C	C - A	b - a			
39			—	A	A - B	c - a	$\frac{HV}{LV}$	Dd4	
				B	B - C	a - b			
				C	C - A	b - c			
40			—	A	A - B	b - c	$\frac{HV}{LV}$	Dd8	
				B	B - C	c - a			
				C	C - A	a - b			
41			—	A	A - B	a - c	$\frac{HV}{LV}$	Dd10	
				B	B - C	b - a			
				C	C - A	c - b			
42			—	A	A - C	a - η	$\frac{HV \cdot \sqrt{3}}{LV}$	Dyn1	
				B	B - A	b - η			
				C	C - B	c - η			
2			C - B A - C B - A	A	A - C	a - c	$\frac{HV \cdot \sqrt{3}}{LV}$	Dy1	NO ACCESSIBLE NEUTRAL ON WYE WINDING
				B	B - A	b - a			
				C	C - B	c - b			
61			C - B A - C B - A	A	A - C	a - b	$\frac{V_H \cdot \sqrt{3}}{V_x}$	Dy3	NO ACCESSIBLE NEUTRAL ON WYE WINDING
				B	B - A	b - c			
				C	C - B	c - a			
62			—	A	A - C	η - b	$\frac{HV \cdot \sqrt{3}}{LV}$	Dyn3	
				B	B - A	η - c			
				C	C - B	η - a			

AUSTRALIAN.050108A1

SPEC TEST NO.	TRANSFORMER CONFIGURATION		EXT. JUMPER	PHASE	WINDING TESTED		CAL. TURN RATIO	VECTOR GROUP	NOTES
	HIGH-VOLTAGE WINDING (H)	LOW-VOLTAGE WINDING (X)			HIGH VOLTAGE WINDING	LOW VOLTAGE WINDING			
3			—	A	A - C	c - η	$\frac{HV \cdot \sqrt{3}}{LV}$	Dyn5	
				B	B - A	a - η			
				C	C - B	b - η			
4			C - B A - C B - A	A	A - C	c - b	$\frac{HV \cdot \sqrt{3}}{LV}$	Dy5	NO ACCESSIBLE NEUTRAL ON WYE WINDING
				B	B - A	a - c			
				C	C - B	b - a			
5			—	A	A - C	η - a	$\frac{HV \cdot \sqrt{3}}{LV}$	Dyn7	
				B	B - A	η - b			
				C	C - B	η - c			
6			C - B A - C B - A	A	A - C	c - a	$\frac{HV \cdot \sqrt{3}}{LV}$	Dy7	NO ACCESSIBLE NEUTRAL ON WYE WINDING
				B	B - A	a - b			
				C	C - B	b - c			
63			C - B A - C B - A	A	B - C	b - a	$\frac{HV \cdot \sqrt{3}}{LV}$	Dy9	NO ACCESSIBLE NEUTRAL ON WYE WINDING
				B	B - A	c - b			
				C	C - B	a - c			
64			—	A	A - C	b - η	$\frac{HV \cdot \sqrt{3}}{LV}$	Dyn9	
				B	B - A	c - η			
				C	C - B	a - η			
7			—	A	A - C	η - c	$\frac{HV \cdot \sqrt{3}}{LV}$	Dyn11	
				B	B - A	η - a			
				C	C - B	η - b			
8			C - B A - C B - A	A	A - C	b - c	$\frac{HV \cdot \sqrt{3}}{LV}$	Dy11	NO ACCESSIBLE NEUTRAL ON WYE WINDING
				B	B - A	c - a			
				C	C - B	a - b			
45			B - C C - A A - B	A	A - B	a - η	$\frac{3}{2} \cdot \frac{HV}{LV}$	Dzn0	
				B	B - C	b - η			
				C	C - A	c - η			
46			B - C C - A A - B	C	A - B	η - b	$\frac{3}{2} \cdot \frac{HV}{LV}$	Dzn2	
				A	B - C	η - c			
				B	C - A	η - a			

AUSTRALIAN.050108A2

SPEC TEST NO.	TRANSFORMER CONFIGURATION		EXT. JUMPER	PHASE	WINDING TESTED		CAL. TURN RATIO	VECTOR GROUP	NOTES
	HIGH-VOLTAGE WINDING (H)	LOW-VOLTAGE WINDING (X)			HIGH VOLTAGE WINDING	LOW VOLTAGE WINDING			
47			—	A	A-B	c-b	$\frac{HV}{LV}$	Dz2	NO ACCESSIBLE NEUTRAL
				B	B-C	a-c			
				C	C-A	b-a			
48			B-C C-A A-B	A	A-B	c-η	$\frac{3}{2} \cdot \frac{HV}{LV}$	Dzn4	
				B	B-C	a-η			
				C	C-A	b-η			
49			—	A	A-B	c-a	$\frac{HV}{LV}$	Dz4	NO ACCESSIBLE NEUTRAL
				B	B-C	a-b			
				C	C-A	b-c			
9			—	A	A-C	a-c	$\frac{HV}{LV}$	Dz0	NO ACCESSIBLE NEUTRAL
				B	B-A	b-a			
				C	C-B	c-b			
10			—	A	A-C	c-a	$\frac{HV}{LV}$	Dz6	NO ACCESSIBLE NEUTRAL
				B	B-A	a-b			
				C	C-B	b-c			
50			B-C C-A A-B	A	A-B	η-a	$\frac{3}{2} \cdot \frac{HV}{LV}$	Dzn6	
				B	B-C	η-b			
				C	C-A	η-c			
51			B-C C-A A-B	A	A-B	b-η	$\frac{3}{2} \cdot \frac{HV}{LV}$	Dzn8	
				B	B-C	c-η			
				C	C-A	a-η			
52			—	A	A-B	b-c	$\frac{HV}{LV}$	Dz8	NO ACCESSIBLE NEUTRAL
				B	B-C	c-a			
				C	C-A	a-b			
53			B-C C-A A-B	A	A-B	η-c	$\frac{3}{2} \cdot \frac{HV}{LV}$	Dzn10	
				B	B-C	η-a			
				C	C-A	η-b			
54			—	A	A-B	a-c	$\frac{HV}{LV}$	Dz10	NO ACCESSIBLE NEUTRAL
				B	B-C	b-a			
				C	C-A	c-b			

AUSTRALIAN.050108A3

SPEC TEST NO.	TRANSFORMER CONFIGURATION		EXT. JUMPER	PHASE	WINDING TESTED		CAL. TURN RATIO	VECTOR GROUP	NOTES
	HIGH-VOLTAGE WINDING (H)	LOW-VOLTAGE WINDING (X)			HIGH VOLTAGE WINDING	LOW VOLTAGE WINDING			
11			—	A	A - N	b - a	$\frac{HV}{LV \cdot \sqrt{3}}$	YNd7	
				B	B - N	c - b			
				C	C - N	a - c			
44			—	A	A - N	a - b	$\frac{HV}{LV \cdot \sqrt{3}}$	YNd1	
				B	B - N	b - c			
				C	C - N	c - a			
12			C - B A - C B - A	A	A - C	a - b	$\frac{HV \cdot \sqrt{3}}{LV \cdot 2}$	Yd1	NO ACCESSIBLE NEUTRAL ON WYE WINDING
				B	B - A	b - c			
				C	C - B	c - a			
13			—	A	A - N	c - a	$\frac{HV}{LV \cdot \sqrt{3}}$	YNd5	
				B	B - N	a - b			
				C	C - N	b - c			
14			C - B A - C B - A	A	A - C	c - a	$\frac{HV \cdot \sqrt{3}}{LV \cdot 2}$	Yd5	NO ACCESSIBLE NEUTRAL ON WYE WINDING
				B	B - A	a - b			
				C	C - B	b - c			
15			C - B A - C B - A	A	A - C	b - a	$\frac{HV \cdot \sqrt{3}}{LV \cdot 2}$	Yd7	NO ACCESSIBLE NEUTRAL ON WYE WINDING
				B	B - A	c - b			
				C	C - B	a - c			
16			—	A	A - N	a - c	$\frac{HV}{LV \cdot \sqrt{3}}$	YNd11	
				B	B - N	b - a			
				C	C - N	c - b			
17			C - B A - C B - A	A	A - C	a - c	$\frac{HV \cdot \sqrt{3}}{LV \cdot 2}$	Yd11	NO ACCESSIBLE NEUTRAL ON WYE WINDING
				B	B - A	b - a			
				C	C - B	c - b			
18			—	A	A - N	η - a	$\frac{HV}{LV}$	YNyn6	
				B	B - N	η - b			
				C	C - N	η - c			
19			B - N C - N A - N	A	A - N	a - b	$\frac{HV}{LV}$	YNy0	NO ACCESSIBLE NEUTRAL ON LOW VOLTAGE WINDING
				B	B - N	b - c			
				C	C - N	c - a			

AUSTRALIAN.050108A4

SPEC TEST NO.	TRANSFORMER CONFIGURATION		EXT. JUMPER	PHASE	WINDING TESTED		CAL. TURN RATIO	VECTOR GROUP	NOTES
	HIGH-VOLTAGE WINDING (H)	LOW-VOLTAGE WINDING (X)			HIGH VOLTAGE WINDING	LOW VOLTAGE WINDING			
20			c-h a-h b-h	A	A-C	a-η	$\frac{HV}{LV}$	Yyn0	NO ACCESSIBLE NEUTRAL ON HIGH VOLTAGE WINDING
				B	B-C	b-η			
				C	C-B	c-η			
43			—	A	A-N	a-η	$\frac{HV}{LV}$	YNyn0	
				B	B-N	b-η			
				C	C-N	c-η			
21			—	A	A-C	a-c	$\frac{HV}{LV}$	Yy0	NO ACCESSIBLE NEUTRAL
				B	B-A	b-a			
				C	C-B	c-b			
22			B-N C-N A-N	A	A-N	b-a	$\frac{HV}{LV}$	YNy6	NO ACCESSIBLE NEUTRAL ON LOW VOLTAGE WINDING
				B	B-N	c-b			
				C	C-N	a-c			
23			c-h a-h b-h	A	A-C	η-a	$\frac{HV}{LV}$	Yyn6	NO ACCESSIBLE NEUTRAL ON HIGH VOLTAGE WINDING
				B	B-A	η-b			
				C	C-B	η-c			
24			—	A	A-C	c-a	$\frac{HV}{LV}$	Yy6	NO ACCESSIBLE NEUTRAL
				B	B-A	a-b			
				C	C-B	b-c			
65			—	A	A-C	a-η	$\frac{V_H \cdot \sqrt{3}}{V_x}$	YNzn1	
				B	B-A	b-η			
				C	C-B	c-η			
25			—	A	A-C	a-η	$\frac{V_H \cdot \sqrt{3}}{LV}$	Yzn1	NO ACCESSIBLE NEUTRAL ON WYE WINDING
				B	B-A	b-η			
				C	C-B	c-η			
26			C-B A-C B-A	A	A-C	a-b	$\frac{HV \cdot \sqrt{3}}{LV \cdot 2}$	Yz1	NO ACCESSIBLE NEUTRAL
				B	B-A	b-c			
				C	C-B	c-a			
27			—	A	A-C	c-η	$\frac{HV \cdot \sqrt{3}}{LV}$	Yzn5	NO ACCESSIBLE NEUTRAL ON WYE WINDING
				B	B-A	a-η			
				C	C-B	b-η			

AUSTRALIAN.050108A5

SPEC TEST NO.	TRANSFORMER CONFIGURATION		EXT. JUMPER	PHASE	WINDING TESTED		CAL. TURN RATIO	VECTOR GROUP	NOTES
	HIGH-VOLTAGE WINDING (H)	LOW-VOLTAGE WINDING (X)			HIGH VOLTAGE WINDING	LOW VOLTAGE WINDING			
28			C-B A-C B-A	A	A-C	c-a	$\frac{HV \cdot \sqrt{3}}{LV \cdot 2}$	Yz5	NO ACCESSIBLE NEUTRAL
				B	B-A	a-b			
				C	C-B	b-c			
66			—	A	A-C	η-a	$\frac{V_H \cdot \sqrt{3}}{V_X}$	YNzn7	
				B	B-A	η-b			
				C	C-B	η-c			
29			—	A	A-C	η-a	$\frac{HV \cdot \sqrt{3}}{LV}$	Yzn7	NO ACCESSIBLE NEUTRAL ON WYE WINDING
				B	B-A	η-b			
				C	C-B	η-c			
30			C-B A-C B-A	A	A-C	b-a	$\frac{HV \cdot \sqrt{3}}{LV \cdot 2}$	Yz7	NO ACCESSIBLE NEUTRAL
				B	B-A	c-b			
				C	C-B	a-c			
67			—	A	A-C	η-c	$\frac{V_H \cdot \sqrt{3}}{V_X}$	Yzn11	
				B	B-A	η-a			
				C	C-B	η-b			
31			—	A	A-C	η-c	$\frac{HV \cdot \sqrt{3}}{LV}$	Yz11	NO ACCESSIBLE NEUTRAL ON WYE WINDING
				B	B-A	η-a			
				C	C-B	η-b			
32			C-B A-C B-A	A	A-C	a-c	$\frac{HV \cdot \sqrt{3}}{LV \cdot 2}$	Yz11	NO ACCESSIBLE NEUTRAL
				B	B-A	b-a			
				C	C-B	c-b			
55			b-c c-a a-b	A	A-N	a-b	$\frac{2}{3} \cdot \frac{HV}{LV}$	ZNd0	
				B	B-N	b-c			
				C	C-N	c-a			
56			—	A	A-B	a-b	$\frac{HV}{LV}$	Zd0	NO ACCESSIBLE NEUTRAL ON HIGH VOLTAGE
				B	B-C	b-c			
				C	C-A	c-a			
57			b-c c-a a-b	A	A-N	b-a	$\frac{HV}{LV}$	ZNd6	
				B	B-N	c-b			
				C	C-N	a-c			

AUSTRALIAN.050108A6

SPEC TEST NO.	TRANSFORMER CONFIGURATION		EXT. JUMPER	PHASE	WINDING TESTED		CAL. TURN RATIO	VECTOR GROUP	NOTES
	HIGH-VOLTAGE WINDING (H)	LOW-VOLTAGE WINDING (X)			HIGH VOLTAGE WINDING	LOW VOLTAGE WINDING			
28			C-B A-C B-A	A	A-C	c-a	$\frac{HV \cdot \sqrt{3}}{LV \cdot 2}$	Yz5	NO ACCESSIBLE NEUTRAL
				B	B-A	a-b			
				C	C-B	b-c			
66			—	A	A-C	η-a	$\frac{V_H \cdot \sqrt{3}}{V_X}$	YNzn7	
				B	B-A	η-b			
				C	C-B	η-c			
29			—	A	A-C	η-a	$\frac{HV \cdot \sqrt{3}}{LV}$	Yzn7	NO ACCESSIBLE NEUTRAL ON WYE WINDING
				B	B-A	η-b			
				C	C-B	η-c			
30			C-B A-C B-A	A	A-C	b-a	$\frac{HV \cdot \sqrt{3}}{LV \cdot 2}$	Yz7	NO ACCESSIBLE NEUTRAL
				B	B-A	c-b			
				C	C-B	a-c			
67			—	A	A-C	η-c	$\frac{V_H \cdot \sqrt{3}}{V_X}$	Yzn11	
				B	B-A	η-a			
				C	C-B	η-b			
31			—	A	A-C	η-c	$\frac{HV \cdot \sqrt{3}}{LV}$	Yz11	NO ACCESSIBLE NEUTRAL ON WYE WINDING
				B	B-A	η-a			
				C	C-B	η-b			
32			C-B A-C B-A	A	A-C	a-c	$\frac{HV \cdot \sqrt{3}}{LV \cdot 2}$	Yz11	NO ACCESSIBLE NEUTRAL
				B	B-A	b-a			
				C	C-B	c-b			
55			b-c c-a a-b	A	A-N	a-b	$\frac{2}{3} \cdot \frac{HV}{LV}$	ZNd0	
				B	B-N	b-c			
				C	C-N	c-a			
56			—	A	A-B	a-b	$\frac{HV}{LV}$	Zd0	NO ACCESSIBLE NEUTRAL ON HIGH VOLTAGE
				B	B-C	b-c			
				C	C-A	c-a			
57			b-c c-a a-b	A	A-N	b-a	$\frac{HV}{LV}$	ZNd6	
				B	B-N	c-b			
				C	C-N	a-c			

AUSTRALIAN.050108A6



**Vanguard Instruments
Company, Inc.**

1520 S. Hellman Ave • Ontario, CA 91761 • USA

Phone: 909-923-9390 • Fax: 909-923-9391

www.vanguard-instruments.com

Copyright © 2010 by Vanguard Instruments Company, Inc.

ATRT-03/03A/03B S2 User's Manual • Revision 2.0 • August 10, 2010 • TA